

DOCUMENTATION - DOKUMENTATION - DOCUMENTACIÓN

POMPE / PUMP / PUMPE / BOMBA

EOS 10-C18

AIRMIX®

Manual : 582.031.110-UK - 2110

Date : 10/10/21

Supersede : 27/05/16

Modif.: Global

TRANSLATION FROM THE ORIGINAL MANUAL

IMPORTANT : Before assembly and start-up, please read and clearly understand all the documents relating to this equipment (professional use only).

THE PICTURES AND DRAWINGS ARE NON CONTRACTUAL. WE RESERVE THE RIGHT TO MAKE CHANGES WITHOUT PRIOR NOTICE..

SAMES KREMLIN SAS

13, chemin de Malacher
38 240 - MEYLAN - France

☎ : 33 (0)4 76 41 60 60

www.sames-kremlin.com



<p align="center">FR</p> <p>Pour une utilisation sûre, il est de votre responsabilité de :</p> <ul style="list-style-type: none"> • D'installer, d'utiliser, d'entretenir et de réparer l'équipement conformément aux préconisations de SAMES KREMLIN ainsi qu'aux réglementations nationales et/ou locales, • Vous assurez que les utilisateurs de cet équipement ont été formés, ont parfaitement compris les règles de sécurité et qu'ils les appliquent. 	<p align="center">UK</p> <p>To ensure safe use of the machinery, it is your responsibility to:</p> <ul style="list-style-type: none"> • Install, use, maintain and repair the machinery in accordance with SAMES KREMLIN's recommendations and national and/or local regulations, • Make sure that the users of the machinery have received proper training and that they have perfectly understood the safety rules and apply them. 	<p align="center">DE</p> <p>Eine sichere Nutzung setzt voraus, dass Sie :</p> <ul style="list-style-type: none"> • die Anlage im Einklang mit den Empfehlungen von SAMES KREMLIN sowie mit den nationalen und/oder lokalen Bestimmungen installieren, verwenden, warten und reparieren, • sich vergewissern, dass die Nutzer dieser Anlage angemessen geschult wurden, die Sicherheitsbestimmungen verstanden haben und sie anwenden.
<p align="center">ES</p> <p>Para una utilización segura, será de su responsabilidad:</p> <ul style="list-style-type: none"> • instalar, utilizar, efectuar el mantenimiento y reparar el equipo con arreglo a las recomendaciones de SAMES KREMLIN y a la normativa nacional y/o local, • cerciorarse de que los usuarios de este equipo han recibido la formación necesaria, han entendido perfectamente las normas de seguridad y las aplican. 	<p align="center">IT</p> <p>Per un uso sicuro, vi invitiamo a:</p> <ul style="list-style-type: none"> • installare, utilizzare, mantenere e riparare l'apparecchio rispettando le raccomandazioni di SAMES KREMLIN, nonché le normative nazionali e/o locali, • accertarvi che gli utilizzatori dell'apparecchio abbiano ricevuto adeguata formazione, abbiano perfettamente compreso le regole di sicurezza e le applichino. 	<p align="center">PT</p> <p>Para uma utilização segura, é da sua responsabilidade:</p> <ul style="list-style-type: none"> • Proceder à instalação, utilização, manutenção e reparação do equipamento de acordo com as preconizações de SAMES KREMLIN, bem como com outros regulamentos nacionais e/ou locais aplicáveis, • Assegurar-se que os utilizadores do equipamento foram devidamente capacitados, compreenderam perfeitamente e aplicam as devidas regras de segurança.
<p align="center">NL</p> <p>Voor een veilig gebruik dient u:</p> <ul style="list-style-type: none"> • het apparaat te installeren, gebruiken, onderhouden en repareren volgens de door SAMES KREMLIN gegeven aanbevelingen en overeenkomstig de nationale en/of plaatselijke reglementeringen, • zeker te stellen dat de gebruikers van dit apparaat zijn opgeleid, de veiligheidsregels perfect hebben begrepen en dat zij die ook toepassen. 	<p align="center">SE</p> <p>För en säker användning av utrustningen ansvarar ni för följande:</p> <ul style="list-style-type: none"> • Installera, använd, underhåll och reparera utrustningen enligt anvisningarna från SAMES KREMLIN och enligt nationella och/eller lokala bestämmelser. • Försäkra er om att användare av denna utrustning erhållit utbildning, till fullo förstått säkerhetsföreskrifterna och tillämpar dem. 	<p align="center">FI</p> <p>Käytön turvallisuuden varmistamiseksi velvollisuutesi on:</p> <ul style="list-style-type: none"> • Noudattaa laitteiston asennuksessa, käytössä, kunnossapidossa ja huollossa SAMES KREMLIN in suosituksia sekä kansallisia ja/tai paikallisia määräyksiä, • Varmistaa, että laitteiston käyttäjät ovat koulutettuja ja ymmärtävät täysin turvallisuusmääräykset ja miten niitä sovelletaan.
<p align="center">PL</p> <p>Dla zapewnienia bezpiecznego użytkowania na użytkownika spoczywa obowiązek:</p> <ul style="list-style-type: none"> • Instalowania, użytkowania, konserwacji i naprawy urządzenia zgodnie z zaleceniami firmy SAMES KREMLIN oraz z przepisami miejscowymi, • Upewnienia, że wszyscy przeszkoleni użytkownicy urządzenia zrozumieli zasady bezpieczeństwa i stosują się do nich. 	<p align="center">CS</p> <p>Pro bezpečné používání jste povinni:</p> <ul style="list-style-type: none"> • Nainstalovat, používat, udržovat a opravovat zařízení v souladu s pokyny firmy SAMES KREMLIN a s národními a/nebo místními legislativními předpisy, • Ujistit se, že uživatelé tohoto zařízení byli vyškoleni, že dokonale pochopili bezpečnostní pravidla a že je dodržují. 	<p align="center">SL</p> <p>Za varno uporabo ste dolžni:</p> <ul style="list-style-type: none"> • inštalirati, uporabljati, vzdrževati in popravljati opremo po določilih SAMES KREMLIN in v skladu z veljavnimi nacionalnimi in/ali lokalnimi predpisi, • poskrbeti, da so uporabniki te opreme ustrezno usposobljeni, poznajo varnostne predpise in da jih upoštevajo.
<p align="center">SK</p> <p>V záujme bezpečného je vašou povinnosťou:</p> <ul style="list-style-type: none"> • nainštalovať, používať, udržiavať a opravovať zariadenie v súlade s odporúčaniami spoločnosti SAMES KREMLIN a národnými a/alebo miestnymi predpismi, • uistiť sa, že používatelia tohto zariadenia boli zaškolení, riadne porozumeli pravidlám bezpečnosti a používajú ich. 	<p align="center">HU</p> <p>A biztonságos használat érdekében az Ön felelőssége, hogy:</p> <ul style="list-style-type: none"> • a berendezést a SAMES KREMLIN ajánlásainak valamint a nemzeti és/vagy helyi szabályozásoknak megfelelően helyezze üzembe, használja, tartsa karban és javítsa, • megbizonyosodjon róla, hogy a berendezés felhasználói képzettek, tökéletesen megértették és alkalmazzák a biztonsági előírásokat. 	<p align="center">RO</p> <p>Pentru o utilizare sigură, este responsabilitatea dvs. să:</p> <ul style="list-style-type: none"> • Instalați, utilizați, întrețineți și reparați echipamentul conform instrucțiunilor SAMES KREMLIN precum și reglementărilor naționale și/sau locale, • Vă asigurați că utilizatorii acestui echipament au fost instruiți, au înțeles perfect regulile de securitate și le aplică integral.

Déclaration(s) de conformité au verso de ce document / Declaration(s) of conformity at the back of this document / Konformitätserklärung(en) auf der Rückseite dieser Unterlage / Declaración (es) de conformidad en el reverso de este documento / Dichiarazione/i di conformità sul retro del presente documento / Declaração(ções) de conformidade no verso do documento / Conformiteitsverklaring(en) op de keerzijde van dit document / Försäkran om överensstämmelse på omständiga sida av detta dokument / Vaatimustenmukaisuusvakuutukset tämän asiakirjan kääntöpuolella / Deklaracja(e) zgodności na odwrocie dokumentu / Prohlášení o shodě se nachází/nacházejí na zadní straně tohoto dokumentu / Deklaracija(e) o skladnosti na hrbtni strani tega dokumenta / Vyhlasenie/-a o zhode sa nachádzajú na zadnej strane dokumentu / A dokumentum hátlapján szereplő megfelelőségi nyilatkoz(ok) / Declarații de conformitate pe versoul acestui document



DECLARATION UE DE CONFORMITE
UE DECLARATION OF CONFORMITY
EU- KONFORMITÄTSERKLÄRUNG
DECLARACIÓN UE DE CONFORMIDAD
DICHIARAZIONE DI CONFORMITÀ UE
DECLARAÇÃO UE DE CONFORMIDADE
EU-CONFORMITEITSVERKLARING
EU-FÖRSÄKRAN OM ÖVERENSSTÄMMELSE
EU- VAATIMUKSEN MUKAISUUSVAKUUTUS
DEKLARACJA ZGODNOŚCI UE
EU PROHLÁŠENÍ O SHODĚ
IZJAVA EU O SKLADNOSTI
VYHLÁŠENIE O ZHODE
EU-MEGFELELŐSÉGI NYILATKOZAT
DECLARATIA DE CONFORMITATE UE

Le fabricant / The manufacturer / Der Hersteller / El fabricante / Il produttore / O fabricante / De fabrikant / Tillverkare / Valmistaja / Producent / Výrobce / Proizvajalec / Výrobca / Gyártó / Fabricantul:	SAMES KREMLIN SAS 13, chemin de Malacher 38 240 - MEYLAN - FRANCE Tél. : 33 (0)4 76 41 60 60
---	--

Déclare que le matériel désigné ci-après / Herewith declares that the equipment / erklährt hiermit, dass die / Declara que el material designado a continuación / Dichiaro che il materiale sottoidicato / Declara que o material a seguir designado / verklaart dat de hieronder aangeduide apparatuur / Kungör att den utrustning som anges här nedan / ilmoittaa, että alla mainitut laitteistot / Oświadczam, że wymienione poniżej urządzenia / Prohlašuje, že níže uvedené vybavení / Izjavlja, da je opisana oprema spodaj / Vyhlasuje, že zariadenie uvedené nižšie / Kijelenti, hogy a megjelölt anyag a továbbiakban / Declară că echipamentul precizat mai jos:

POMPES / PUMPS / PUMPEN / BOMBAS / POMPE / POMPEN / PUMPAR / PUMPUT / POMPY / НАСОСЫ

EOS 10-C18

Est conforme à la législation d'harmonisation de l'Union applicable suivante / Is in conformity with the relevant Union harmonisation legislation / Erfüllt die einschlägigen Harmonisierungsrechtsvorschriften der Union / es conforme con la legislación de armonización pertinente de la Unión / è conforme alla pertinente normativa di armonizzazione dell'Unione / in overeenstemming met de desbetteffende harmonisatiewetgeving van de Unie / med den relevanta harmoniserade unionslagstiftningen / on asiaa koskevan unionin yhdenmukaistamislainsäädännön vaatimusten mukainen / jest zgodny z jednostronnymi wymaganiami unijnego prawodawstwa harmonizacyjnego / Shoduje se s následující příslušnou evropskou harmonizační legislativou / V skladu s harmonizirano zakonodajo Unije / Je v súlade s uplatniteľnými harmonizačnými právnymi predpismi EÚ / Megfelel a következő alkalmazandó uniós harmonizációs szabályozásnak / Este conform cu legislația aplicabilă de armonizare de mai jos

Directive ATEX / ATEX Directive / ATEX Richtlinie / Directiva ATEX / Direttiva ATEX / Diretiva ATEX / ATEX-Richtlijn / ATEX-direktivet / ATEX-direktivi / Dyrektywa ATEX / Směrnice ATEX / Direktiva ATEX / Smernica ATEX / ATEX-irányelv	2014/34/UE
---	-------------------



La présente déclaration de conformité est établie sous la seule responsabilité du fabricant / This declaration of conformity is issued under the sole responsibility of the manufacturer / Die alleinige Verantwortung für die Ausstellung dieser Konformitätserklärung trägt der Hersteller / La presente declaración de conformidad se expide bajo la exclusiva responsabilidad del fabricante / La presente dichiarazione di conformità è rilasciata sotto la responsabilità esclusiva del fabbricante / A presente declaração de conformidade é emitida sob a exclusiva responsabilidade do fabricante / Deze conformiteitsverklaring wordt verstrekt onder volledige verantwoordelijkheid van de fabrikant / Denna försäkran om överensstämmelse utfärdas på tillverkarens eget ansvar / Tämä vaatimustenmukaisuusvakuutus on annettu valmistajan yksinomaisella vastuulla / Niniejsza deklaracja zgodności wydana zostaje na wyłączną odpowiedzialność producenta / Toto prohlášení o shodě se vydává na výhradní odpovědnost výrobce / Za izdajo te izjave o skladnosti je odgovoren izključno proizvajalec / Toto vyhlásenie o zhode sa vydáva / na vlastnú zodpovednosť výrobcu / Ezt a megfelelőségi nyilatkozatot a gyártó kizárólagos felelőssége mellett adják ti / Prezenta declarație de conformitate este emisă pe răspunderea exclusivă a producătorului.



Hervé WALTER

Directeur Recherche & Développement / Research & Development Director / Direktor für Forschung & Entwicklung / Director de Investigación y Desarrollo / Direttore Ricerca e sviluppo / Diretor de Pesquisa e desenvolvimento / Manager Onderzoek en Ontwikkeling / Direktör för Forskning och Utveckling / Johtaja tutkimus ja kehitys / Dyrektor ds. Badań i rozwoju / Ředitel výzkumu a vývoje / Direktor za raziskave in razvoj / Riaditeľ pre výskum a vývoj / Kutatási és Fejlesztési Igazgató / Director de cercetare și Dezvoltare

Fait à Meylan, le / Established in Meylan, on / Geschehen zu Meylan, am / En Meylan, a / Redatto a Meylan, / Vastgesteld te Meylan, / Utformat i Meylan, den / Meylan, Ranska, / Sporządzono w Meylan, dnia / Meylan, dnia / V Meylanu, / V Meylan dňa / Kelt Meylanban, / Întocmită la Meylan, pe data de 22/10/2021 - 22/10/2021



INSTALLATION AND SAFETY INSTRUCTIONS

TRANSLATION FROM THE ORIGINAL MANUAL

IMPORTANT : Before assembly and start-up, please read and clearly understand all the documents relating to this equipment (professional use only).

THE PICTURES AND DRAWINGS ARE NON CONTRACTUAL. WE RESERVE THE RIGHT TO MAKE CHANGES WITHOUT PRIOR NOTICE.

SAMES KREMLIN SAS
13, chemin de Malacher
38 240 - MEYLAN - France
☎ : 33 (0)4 76 41 60 60

www.sames-kremlin.com

1. SAFETY INSTRUCTIONS

GENERAL SAFETY INSTRUCTIONS



CAUTION : The equipment can be dangerous if you do not follow our instructions concerning installation and servicing described in this manual and in accordance with applicable European standards and local national safety regulations.

Please carefully read all the instruction literature before operating your equipment.

Only trained operators can use the equipment.

The foreman must ensure that the operator has understood the safety instructions for this equipment as well as the instructions in the manuals for the different parts and accessories.

Read carefully all instruction manuals, label markings before operating the equipment.

Incorrect use may result in injury. This equipment is for professional use only. It must be used only for what it has been designed for. Never modify the equipment. The parts and accessories supplied must be regularly inspected. Defective or worn parts must be replaced.

Guards (motor cover, coupling shields, connectors,...) have been designed for a safe use of the equipment.
The manufacturer will not be held responsible for bodily injury or failure and / or property damage due to destruction, the overshadowing or the partial or total removal of the guards.

Never exceed the equipment components' maximum working pressure.

Comply with regulations concerning safety, fire risks, electrical regulations in force in the country of final destination of the material. Use only products or solvent compatible with the parts in contact with the material (refer to data sheet of the material manufacturer).

PICTOGRAMS

A	D	F	E	C	G
NIP HAZARD	WARNING MOVING ELEVATOR	WARNING MOVING PARTS	WARNING MOVING SHOVEL	DO NOT EXCEED THIS PRESSURE	HIGH PRESSURE HAZARD
H	I	J	K	L	M
RELIEF OR DRAIN VALVE	WARNING HOSE UNDER PRESSURE	WEAR GLASSES OBLIGATORY	WEAR OF GLOVES IS OBLIGATORY	PRODUCT VAPOR HAZARDS	WARNING HOT PARTS OR AREAS
N	P	Q	R	S	T
ELECTRICAL HAZARD	WARNING FIRE HAZARDS	EXPLOSION HAZARDS	GROUNDING	WARNING (USER)	WARNING SERIOUS INJURIES

PRESSURE HAZARDS



Current legislation requires that an **air relief** valve be fitted in the air supply circuit to the air motor to prevent over pressurisation. This safety feature, ensures that it is not possible to supply the air motor with excessive air pressure that may cause injury.

Please ensure that a **material drain valve** is fitted in the fluid circuit to drain and depressurise the circuit. Once depressurised and drained, work /servicing may then commence on the equipment. Please remember to close these valves when restarting the system.

HIGH PRESSURE INJECTION HAZARDS



When working with high pressure equipment, special care is required. Fluid leaks can occur. There is a risk of material being injected to any exposed parts of body, this could cause severe injury :



- medical care must be sought immediately if paint is injected under the skin or in other parts of the body (eyes, fingers).
- never point the spray gun at any one. Never try to stop the spray with your hands or fingers nor with rags or similars.
- **follow the shut down procedure and always depressurize air and fluid circuits** before carrying out any servicing on the gun (cleaning, checking, maintenance of the material or cleaning of the gun nozzles).
- for the guns equipped with a safety device, always lock the trigger when not in use.

FIRE - EXPLOSION - SPARKS - STATIC ELECTRICITY HAZARDS

A poor earth connection, inadequate ventilation, sparks or static electricity can cause an explosion or fire. to avoid these risks when using or servicing SAMES KREMLIN equipment, the following safety procedures must be followed :



- ensure a good earth connection and ground the parts to be handled i.e. solvents, materials, components and equipment,
- ensure adequate ventilation,
- keep working area clean and free from waste solvents, chemicals, or solid waste i.e. rags, paper and empty chemicals drums,
- never use electrical switches / power if in an atmosphere of volatile solvent vapour,
- stop working immediately in case of electrical arcs,
- never store chemicals and solvents in the working area.
- use paint whose flash point is the highest possible to prevent from any formation of gas and inflammable vapours (refer to materials' safety instructions),
- install a cover on the drums to reduce the diffusion of gas and vapours in the spraybooth.

TOXIC PRODUCT HAZARDS



Toxic products or vapours can cause severe injury not only though contact with the body, but also if the products are ingested or inhaled. It is imperative :



- to know the material products and their risks,
- notified or hazardous materials must be stored in accordance with the regulations,
- the material must be stored in an appropriate container, never place materials in a container where there is a risk of spillage or leakage,
- a procedure must be applied for the safe disposal of waste material. It must comply with all prevailing regulations and legislations of the country where the equipment is to be used,
- protective clothing should always be worn in compliance with the material manufacturers' recommendations,
- depending on the application and chemical safety instructions, safety glasses, hearing protective earplug, gloves, foot wear, protective masks and possible breathing equipment should be worn to comply with the regulations (Refer to chapter "Safety equipment of SAMES KREMLIN selection guide).



CAUTION!

It is forbidden to use material containing high concentrations of halogenated hydrocarbon solvents with **aluminium** or **zinc fillers**. Non-compliance with the instructions may cause explosion risk causing serious or fatal injury.



EQUIPMENT REQUIREMENTS

**Guards (motor cover, coupling shields, connectors,...) have been designed for a safe use of the equipment.
The manufacturer will not be held responsible for bodily injury or failure and / or property damage due to destruction, the overshadowing or the partial or total removal of the guards.**



PUMP

Before carrying out any work, it is imperative to read and clearly understand the disassembly and reassembly instructions before servicing. The operator must understand the equipment and the safety instructions. These instructions are available in the equipment manuals.



The air motor is designed to be mounted with a pump. Never modify any components or couplings. When operating, please keep hands away from moving parts. Before starting up the equipment, please read the PRESSURE RELIEF instructions. Please ensure that any relief or drain valves fitted are in good working order.

HOSES

- Keep hoses out of circulation areas, moving parts or hot surfaces,
- Never expose product hoses to temperature higher than + 60°C / 140° F or lower than 0°C / 32° F,
- Never pull or use the hoses to move the equipment,
- Tighten all fittings as well as the hoses before operating the equipment,
- Check the hoses regularly; change them if they are damaged,
- Never exceed the maximum working pressure (MWP) indicated on the hose.

USED PRODUCTS

Considering the wide variety of products that are available and can be used in our equipment it is impossible to check and make recommendations for all chemical data, regarding the risks of possible chemical attack and their long term chemical reaction

SAMES KREMLIN can not be held liable for :

- compatibility of wetted parts,
- risks to staff and the surroundings,
- for worn or defective parts, for faulty equipment or units, or the quality of final product.

It is the responsibility of the user to know and prevent any possible risks such as toxic vapours, fires or explosions. He shall determine the risks of immediate reactions or pursuant to repeated exposures of the staff,

SAMES KREMLIN shall not be liable for physical injuries, direct or indirect material damages caused by the use of chemicals.

2. HANDLING

 **Check the weight and the dimensions of the equipment**
(🔗 refer to 'Technical features' section of the instruction manual)

If weight and dimensions are too important, the unloading must be carried out by means of a forklift or any other appropriate means with a qualified personnel and in a clear horizontal area to prevent from risks of damage injury or an accident.

The centre of gravity is not in the centre of the machine : carry out by hand a stability-test after having lifted the whole at 10 cm / 3.937" maximum.

After the unloading, the handling of the whole (eg: elevator pump) is carried out by means of a pallet truck taking the bottom part of the frame.

Remark : Each pump motor is fitted with a ring. The ring is designed for the hoisting of one pump and can not be used for the handling of the complete assembly.

3. STORING

Storing before installation :

- Storing ambient temperature : 0 / +50 °C / 0 / +122°F
- Protect the whole against dust, water trickling, dampness and shocks.

Storing after installation :

- Operating temperature : +15 / +35 °C / +59 / +138.2° F
- Protect the whole against dust, water trickling, dampness and shocks.

4. INSTALLATION OF THE EQUIPMENT

The machine is installed on a stable horizontal floor (for eg a concrete flag).

The machine shall be made stable by the use of holding down bolts or by the use of other anchoring methods, strong enough to prevent unintended bodily movement of the equipment.



To avoid risks caused by static electricity, the equipment as well as its components must be grounded.

- **For the pumping equipments** (pumps, pneumatic rams, frame...), a section wire of 2.5 mm² is fixed on the material. Use this wire to connect the material to "the general ground". In case of severe environments (mechanical protection of the wire of earthing insufficient, vibrations, mobile material...) where function damages at the ground are probable, the user have to replace the provided wire of 2.5 mm² by a device more adapted to its environment (wire with a more important section, bonding strip, fixing by thimble with eyelet...).

The continuity of the ground must be controlled by a qualified electrician. If the continuity of the ground is not ensured, check the terminal, the wire and the earthing point. **Never** use the material without have solved this problem.

- In the severe cases of environments (mechanical protection of the wire of earthing insufficient, vibrations, mobile material...) where damages of the function put at the ground are probable, the user will have to replace the wire of 2.5 mm² provided, by a device more adapted to its environment (wire of more important section, bonding strip, fixing by thimble with eyelet...),
- **The gun** must be 'grounded' via a material hose or an air hose. In case of spraying by means of a gun with cup, the air hose must be conductive,
- **The materials to be painted** must also be grounded.

All the materials situated in the working area shall be grounded.



- **Never store** more than necessary inflammable materials inside the working area,
- The materials must be stored into **approved drums** and grounded,
- Use only grounded **metals containers** for the use of cleaning solvents,
- **Cardboard and paper are prohibited.**

5. MARKING OF THE EQUIPMENT

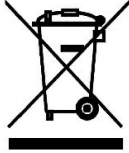

Each equipment has a label plate with the name of the manufacturer, the equipment part number, the interesting informations to use correctly the equipment (pressure, voltage,...) and sometimes the above pictogram.

The equipment is designed with and consists of high quality materials and components which can be re-used.

The 2012/19/UE European Directive covers all equipments with a crossed-out bin pictogram. Please inform yourself about the collection systems for electric and electronic equipments.

Please act in accordance with local rules and **do not dispose of old equipment with household wastes**. A correct disposal of old equipment will help prevent negative consequences for the environment and health.

**POMPE / PUMP / PUMPE / BOMBA
10-C18**

NOTICE ORIGINALE
/ TRANSLATION FROM THE ORIGINAL MANUAL
/ ÜBERSETZUNG DER ORIGINAL BETRIEBSANLEITUNG
/ TRADUCCIÓN DEL LIBRO ORIGINAL

**La pompe est soumise à la directive ATEX et ne doit en aucun cas être modifiée.
Le non-respect de cette préconisation ne saurait engager notre responsabilité.
/ The pump is manufactured under the ATEX agreement and can not be modified.
SAMES KREMLIN will not be held responsible for any failure to comply with that
instruction.**

**/ Diese Pumpe hat die ATEX Zulassung, deswegen darf sie nie verändert werden. Bei
Nichtbeachtung dieser Anordnung, können wir keine Verantwortung für eine
einwandfreie, regelkonforme Funktion der Pumpe übernehmen.**

**/ La bomba es de conformidad a la directiva ATEX y no debe ser modificada, en ningún
caso. SAMES KREMLIN no se hace responsable de que esta preconización no sea
respetada.**

**Des protecteurs (capot moteur, protecteur d'accouplement, carters,...) sont mis en place pour
une utilisation sûre du matériel.**

**Le fabricant ne peut être tenu pour responsable en cas de dommages corporels ainsi que des
pannes et / ou endommagement du matériel résultant de la destruction, de l'occultation ou du
retrait total ou partiel des protecteurs.**

**/ Guards (air motor cover, coupling shields, housings ...) have been designed for safe use of
the equipment. The manufacturer will not be held responsible for bodily injury or failure and /
or damage to property due to removal or partial removal of the guards.**

**/ Schutzvorrichtungen an diesem Gerät, wie Motorhaube, Kupplungsschutz, Gehäuse, ggf.
Erdungskabel, sowie weitere Vorrichtungen, wurden für eine sichere Benutzung dieses
Gerätes entwickelt und angebracht. Der Hersteller lehnt jede Verantwortung für
Körperschäden, Fehlfunktionen, Beschädigung der Geräte, und jegliche andere Fehler ab, die
durch die ganze oder teilweise Entfernung, Modifikation oder unsachgemäße Handhabung der
Schutzvorrichtungen oder anderen Geräteteilen entstehen.**

**/ Protectores (capó motor, protector de acoplamiento, cárteres,...) se colocan para una
utilización segura del material. El fabricante no se hace responsable, en caso de daños
personales, así como de las averías y / o daños del material, resultantes de la destrucción, la
ocultación o la retirada total o parcial de los protectores.**

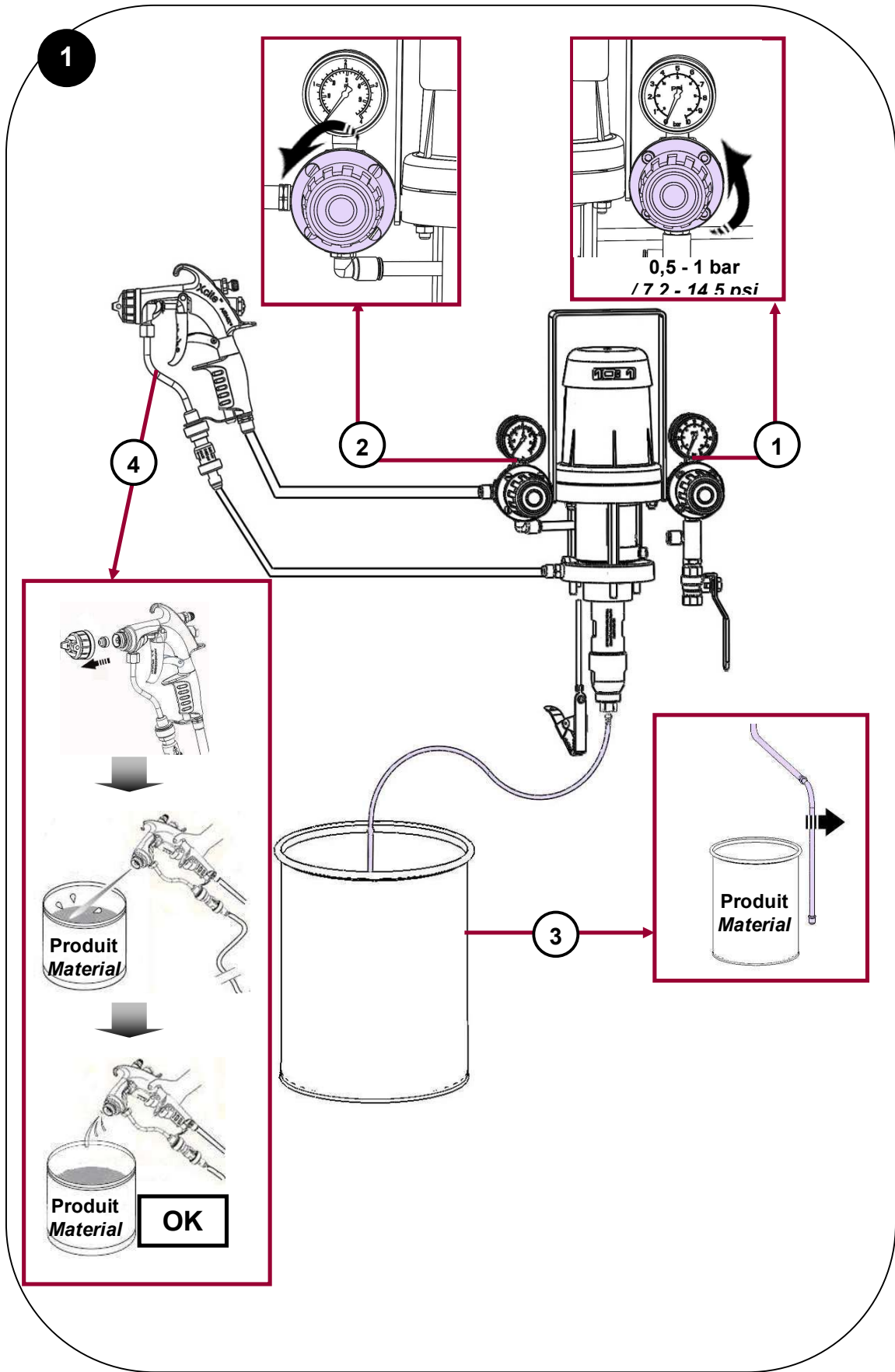

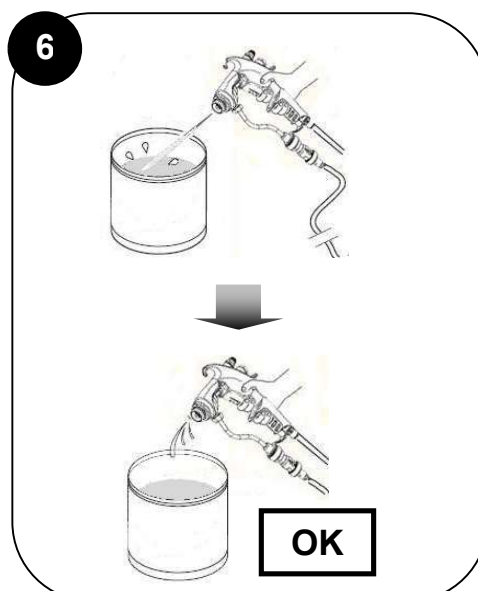
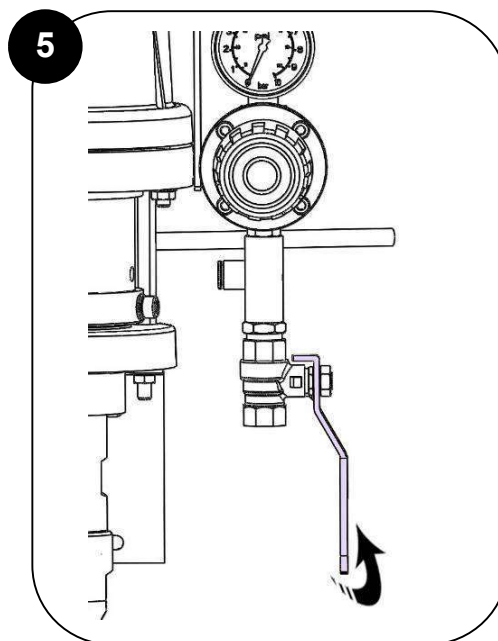
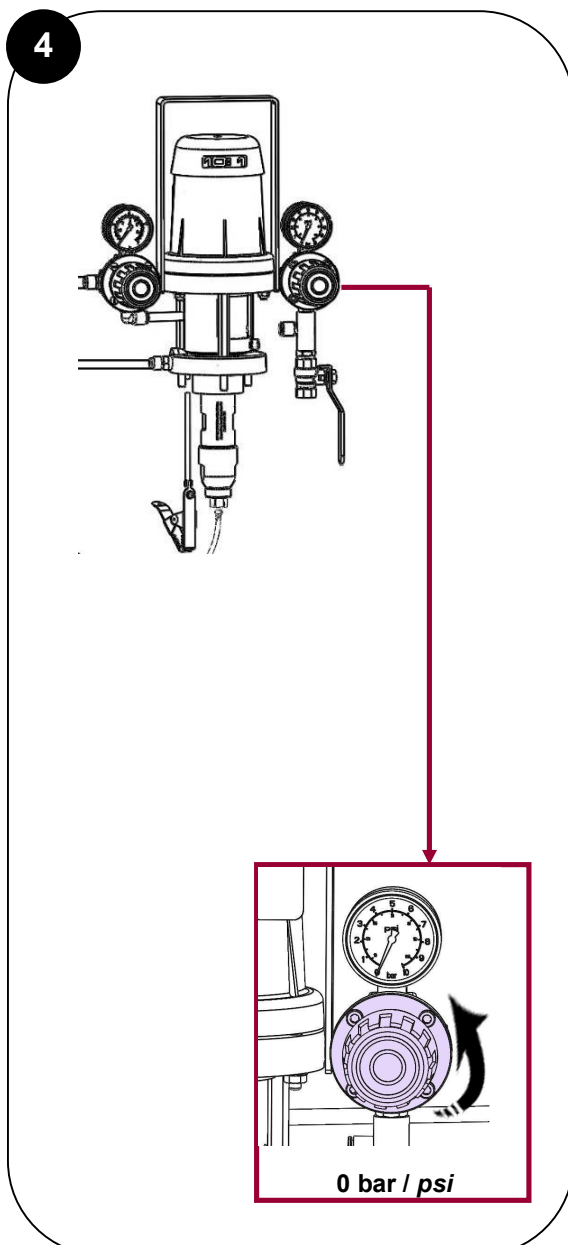
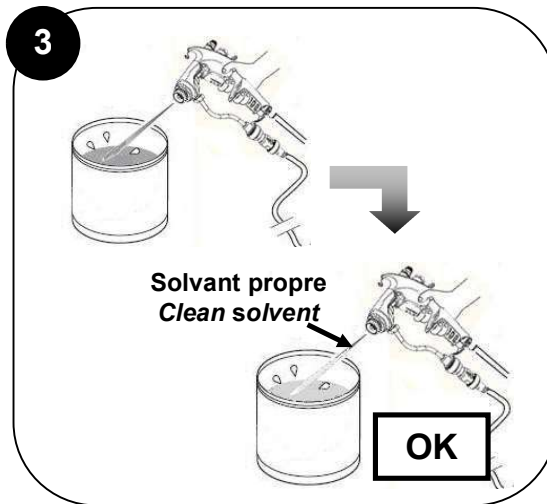
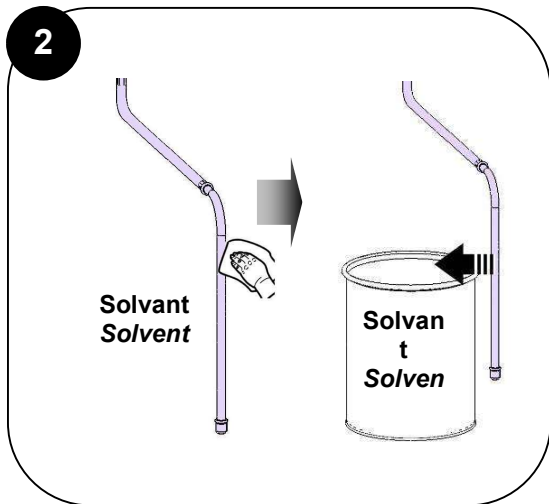

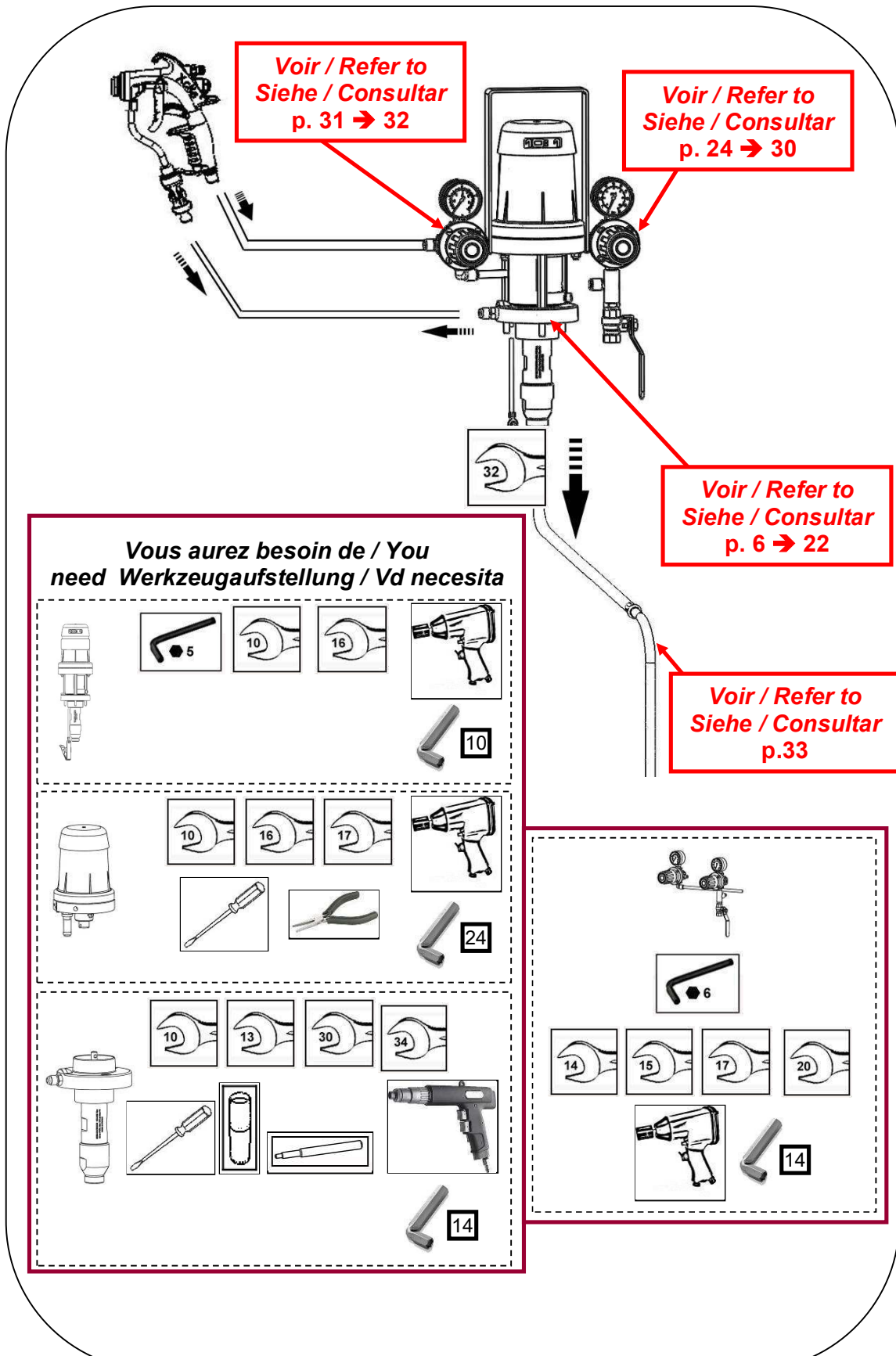

Voir / Refer to
Siehe / Consultar
p. 31 → 32

Voir / Refer to
Siehe / Consultar
p. 24 → 30

Voir / Refer to
Siehe / Consultar
p. 6 → 22

Voir / Refer to
Siehe / Consultar
p.33

Vous aurez besoin de / You need Werkzeugaufstellung / Vd necesita

**Graisses, colles et couple de serrage / Greases, adhesives and screwing torque
/ Fette, Kleber und Anziehdrehmoment / Grasas, colas y par de apriete**

Repère / Index / Pos. / Índice	Instructions / Montage-Hinweis / Instrucciones	Désignation / Description / Bezeichnung / Descripción	Référence / Part number / Artikel-Nr. / Referencia
A 1	Graisse PTFE	Tube de graisse "TECHNILUB" (10 ml)	560.440.101
	PTFE grease	PTFE grease (10 ml / 0.0026 US gal)	
	PTFE-Fett	PTFE Fett (10 ml)	
	Grasa PTFE	Tubo de grasa "TECHNILUB" (10 ml)	
A 2	Graisse anti-seize	Boîte de graisse (450 g)	560.420.005
	Anti-seize grease	Grease box (450 g / 0.99 lb)	
	Grafit Fett	Grafit Fett (450 g Dose)	
	Grasa anti-seize	Caja de grasa anti-seize (450 g)	
C 1	Colle Anaérobie Tube étanche	Loctite 577 (250 ml)	554.180.015
	Medium strength Aneorobic Pipe sealant	Loctite 577 (250 ml / 0.066 US gal)	
	Mittelfester anaerober Kleber	Loctite 577 (250 ml)	
	Cola PTFE (para la estanqueidad)	Loctite 577 (250 ml)	
C 2	Colle Anaérobie frein filet faible	Loctite 222 (50 ml)	554.180.010
	Low strength - Anaerobic Adhesive	Loctite 222 (50 ml / 0.013 US gal)	
	Niedrigfester anaerober Kleber	Loctite 222 (50 ml)	
	Cola freno suave	Loctite 222 (50 ml)	
S 1	Couple de serrage : 4 Nm		
	Screwing torque : 4 Nm / 2.95 Ft/Lbs		
	Anziehdrehmoment : 4 Nm		
	Par de apriete : 4 Nm		

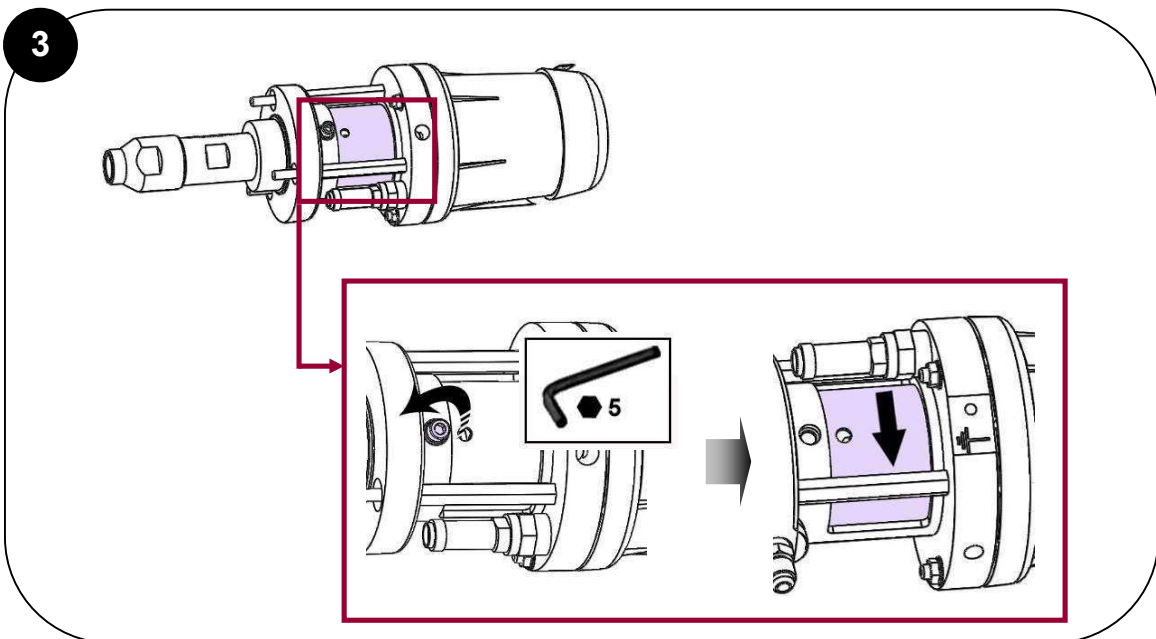
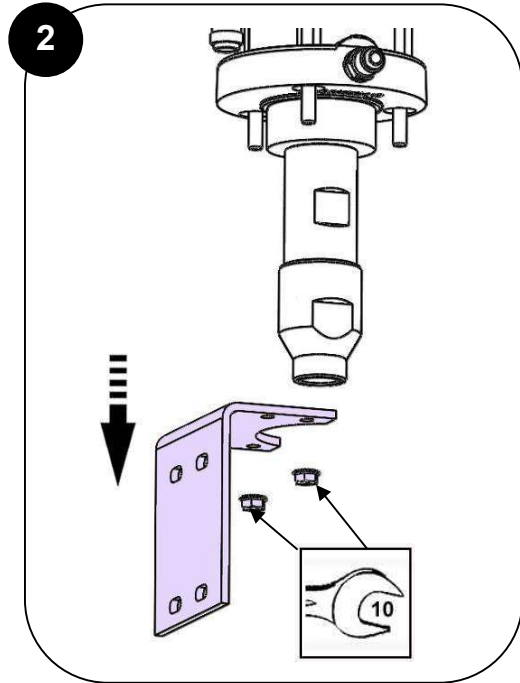
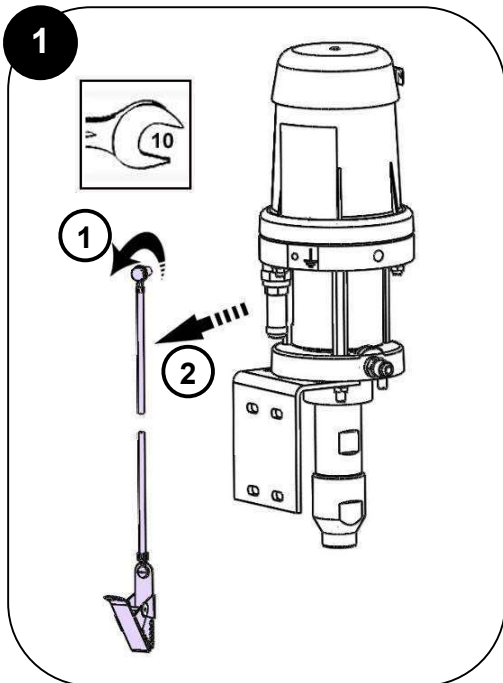
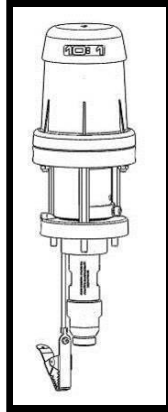

4

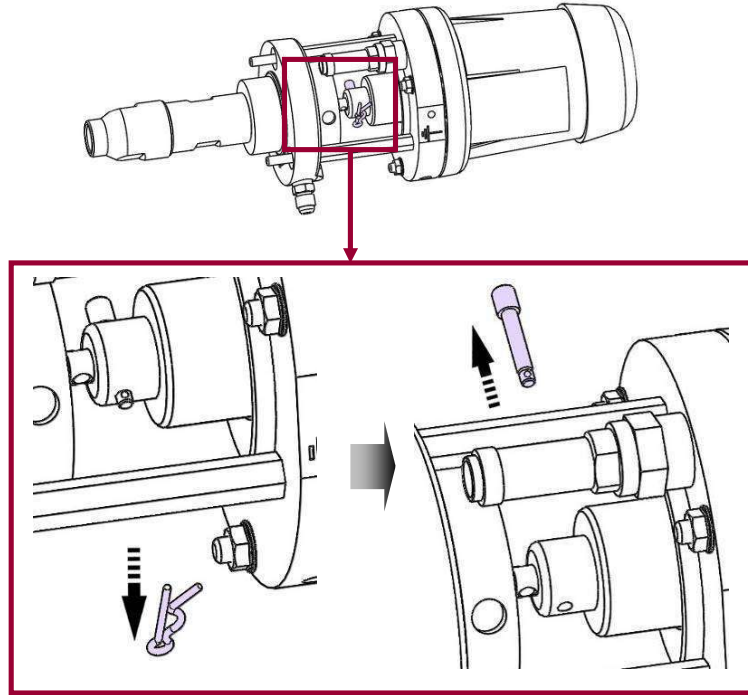

5

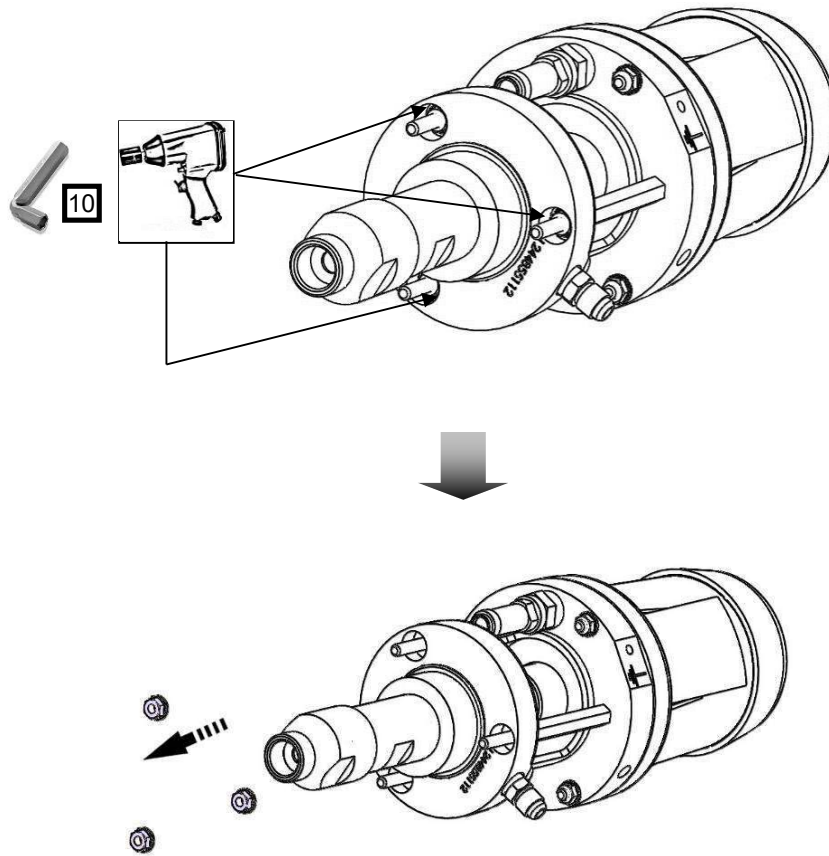

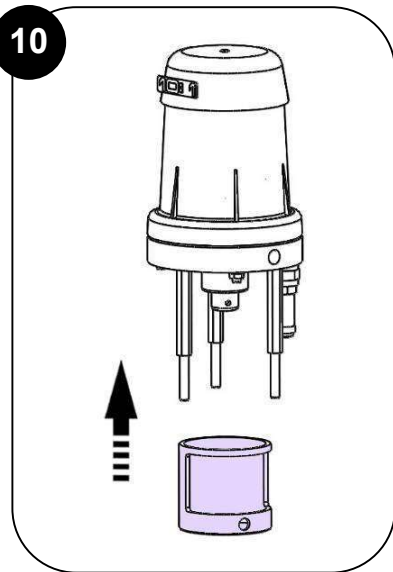
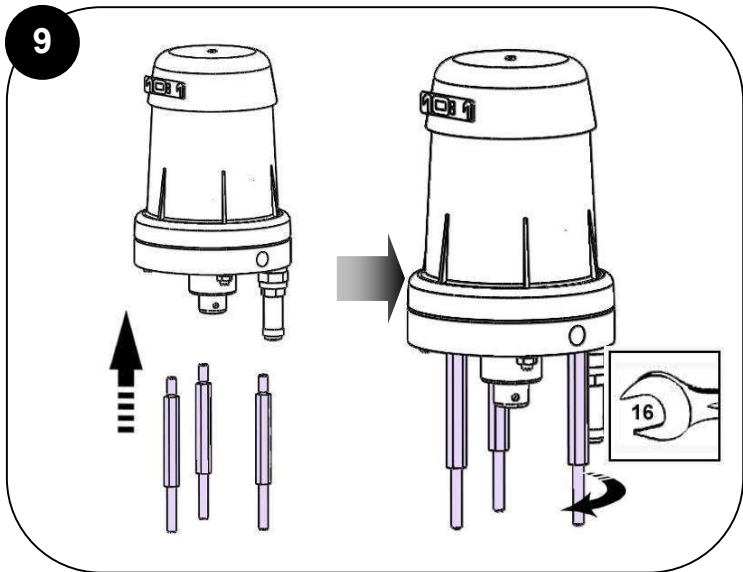
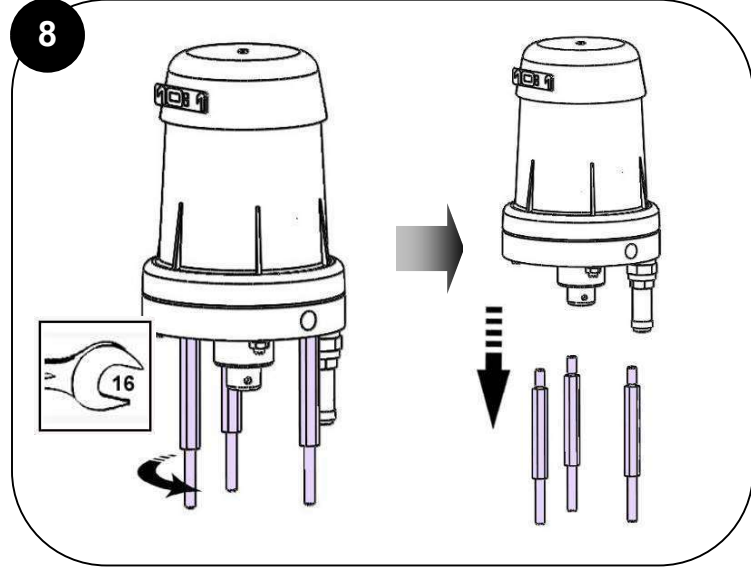
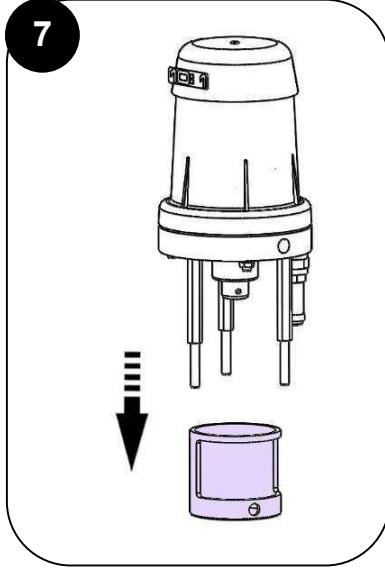
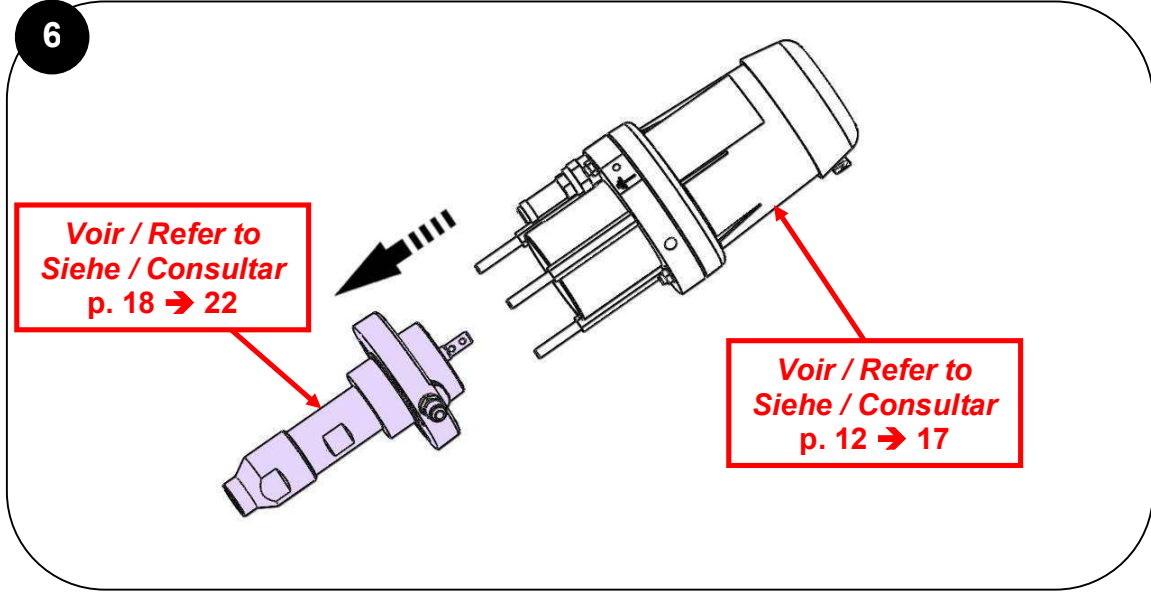

11

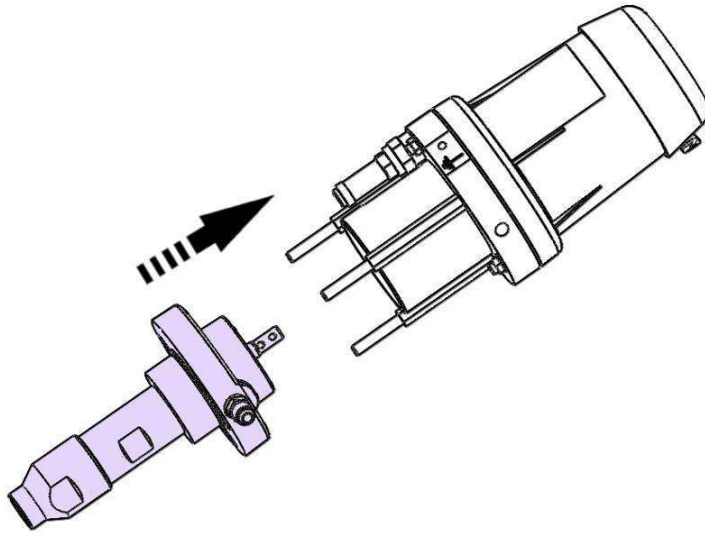

12

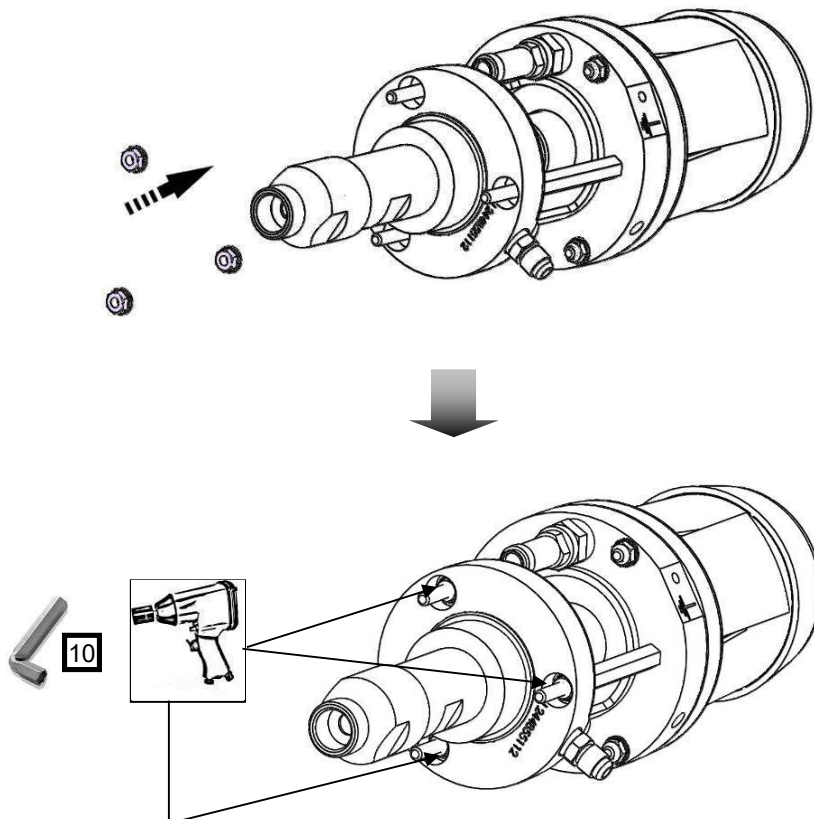

13

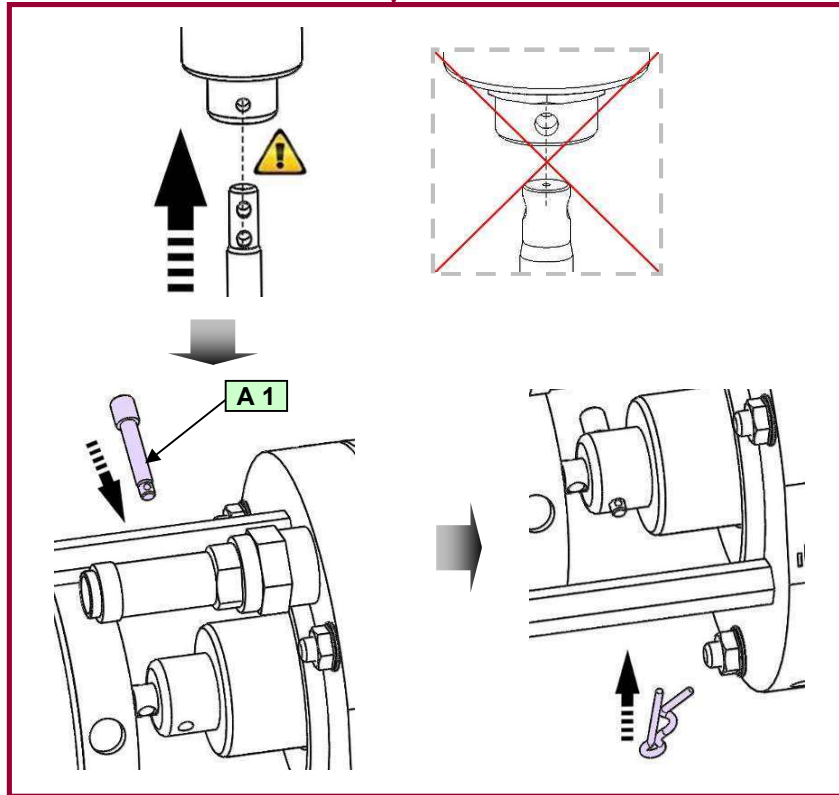
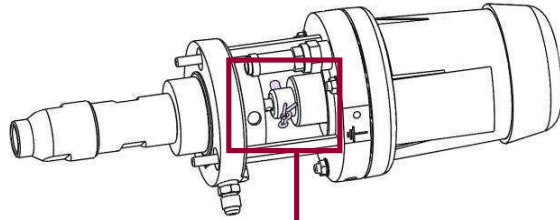

14

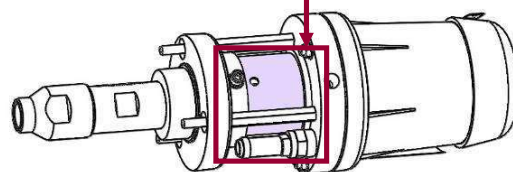
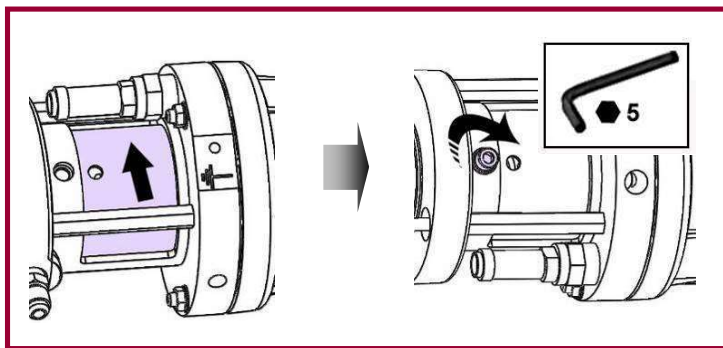

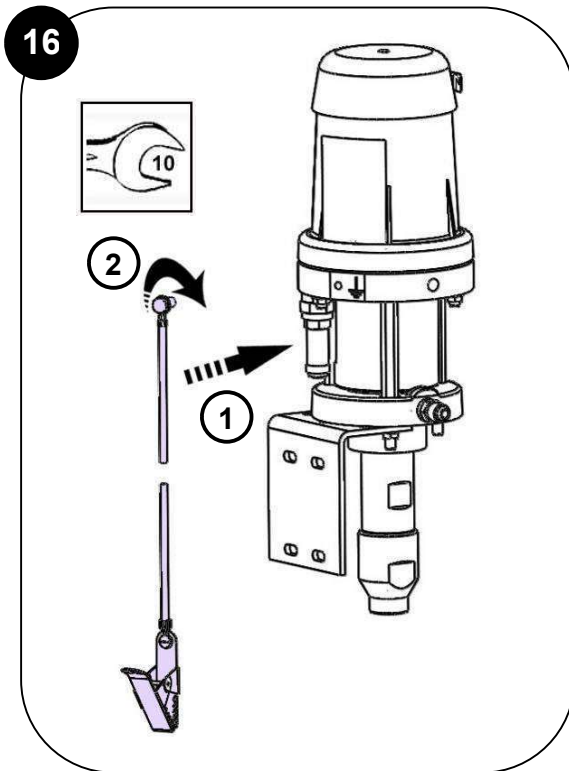
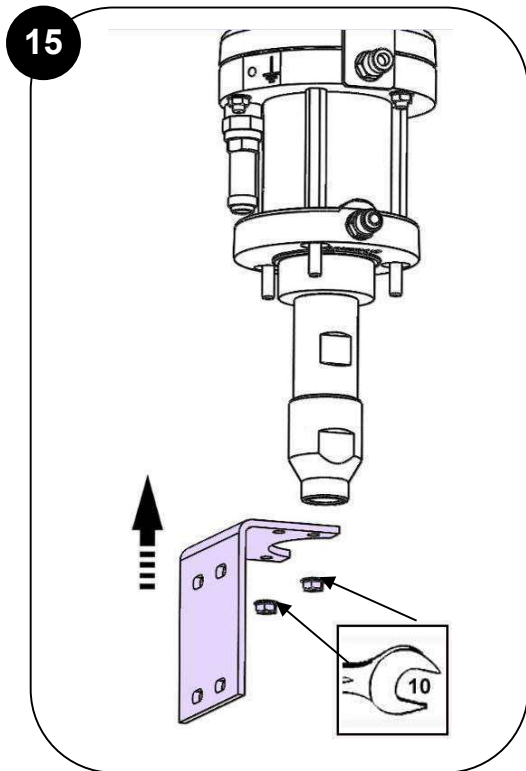

Des protecteurs (capot moteur, protecteur d'accouplement, carters,...) sont mis en place pour une utilisation sûre du matériel.

Le fabricant ne peut être tenu pour responsable en cas de dommages corporels ainsi que des pannes et / ou endommagement du matériel résultant de la destruction, de l'occultation ou du retrait total ou partiel des protecteurs.

/ Guards (air motor cover, coupling shields, housings ...) have been designed for safe use of the equipment. The manufacturer will not be held responsible for bodily injury or failure and / or damage to property due to removal or partial removal of the guards.

/ Schutzvorrichtungen an diesem Gerät, wie Motorhaube, Kupplungsschutz, Gehäuse, ggf. Erdungskabel, sowie weitere Vorrichtungen, wurden für eine sichere Benutzung dieses Gerätes entwickelt und angebracht. Der Hersteller lehnt jede Verantwortung für Körperschäden, Fehlfunktionen, Beschädigung der Geräte, und jegliche andere Fehler ab, die durch die ganze oder teilweise Entfernung, Modifikation oder unsachgemäße Handhabung der Schutzvorrichtungen oder anderen Geräteteilen entstehen.

/ Protectores (capó motor, protector de acoplamiento, cárteres,...) se colocan para una utilización segura del material. El fabricante no se hace responsable, en caso de daños y / o daños del material, resultantes de la destrucción, la ocultación o la retirada total o parcial de los protectores.

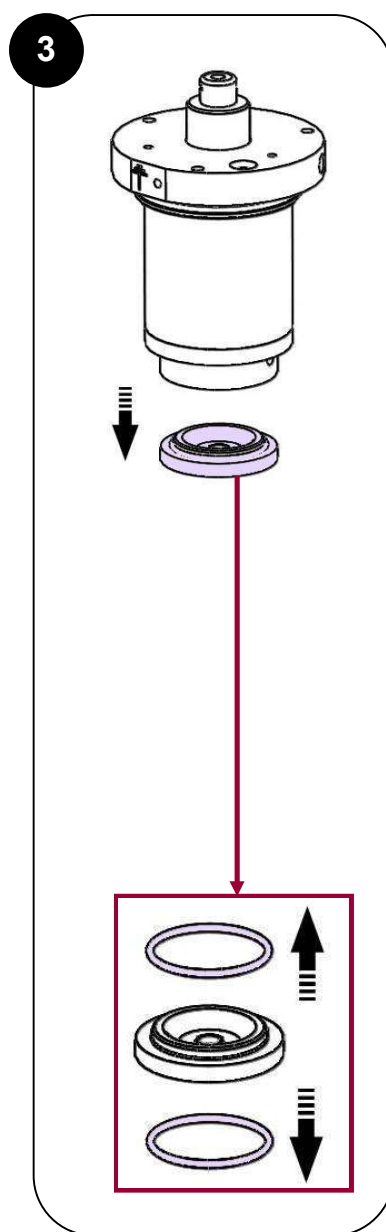
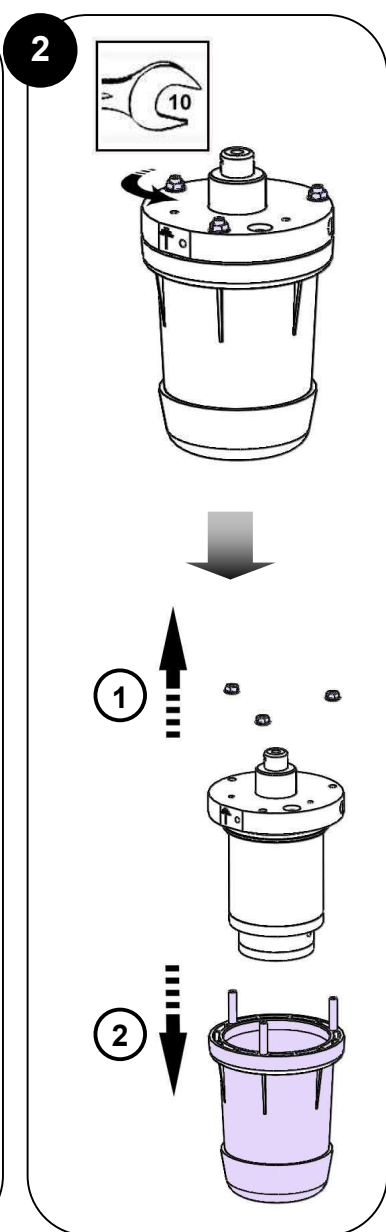
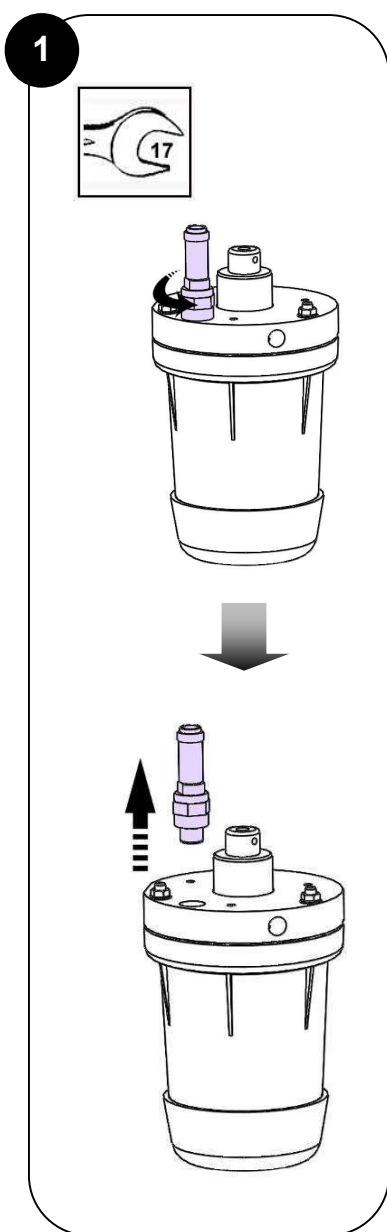
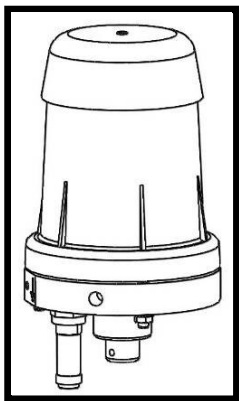

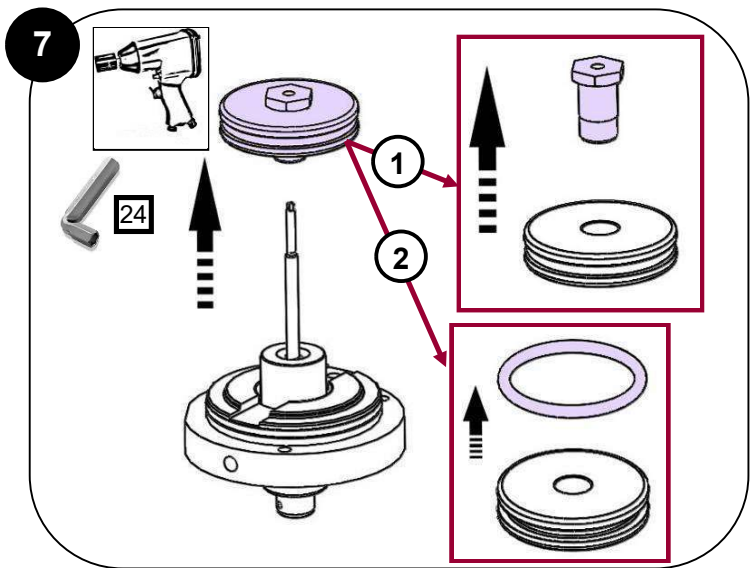
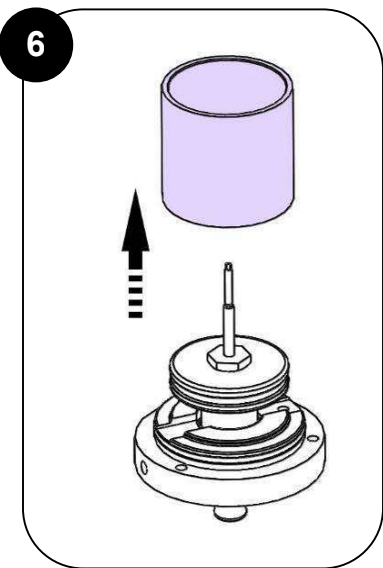
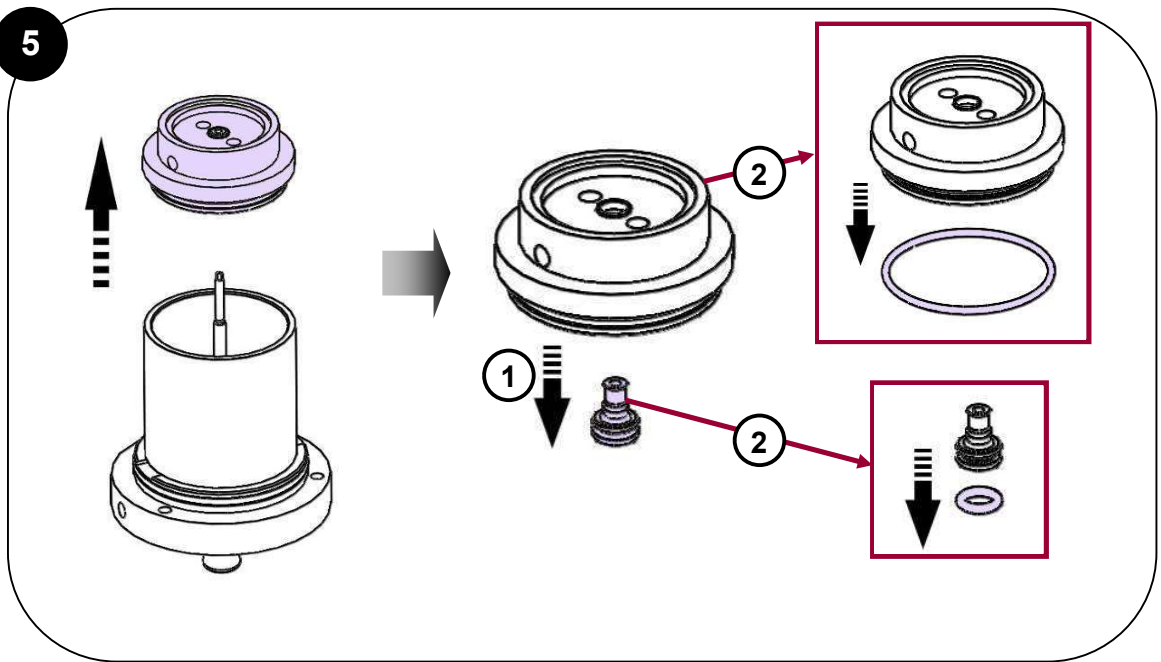
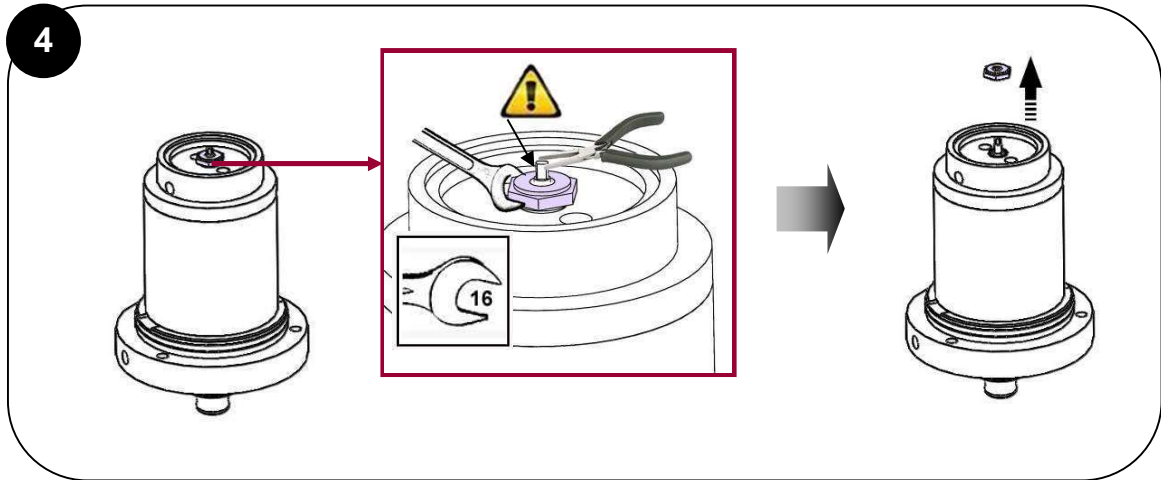

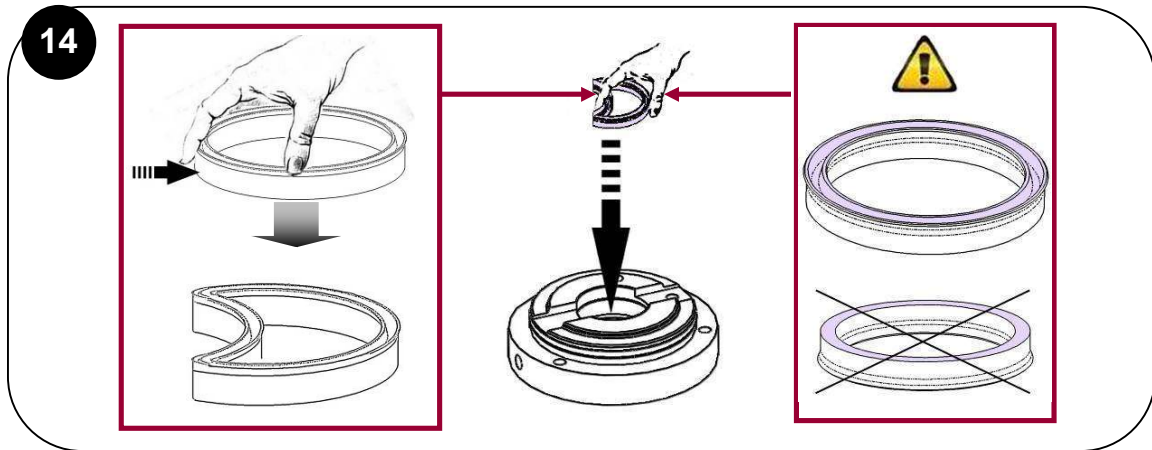
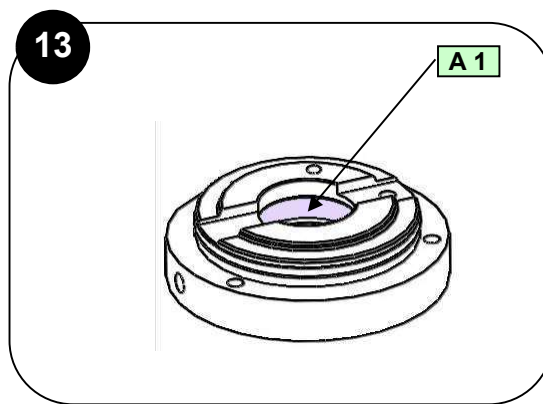
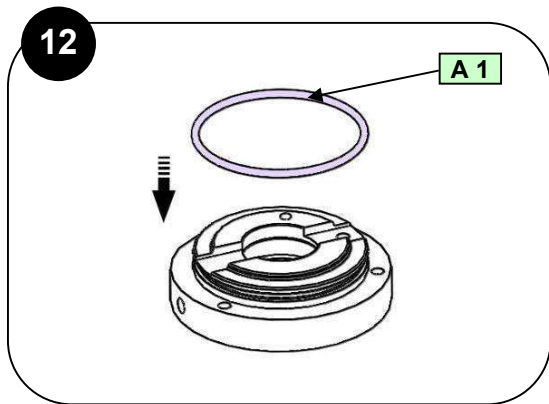
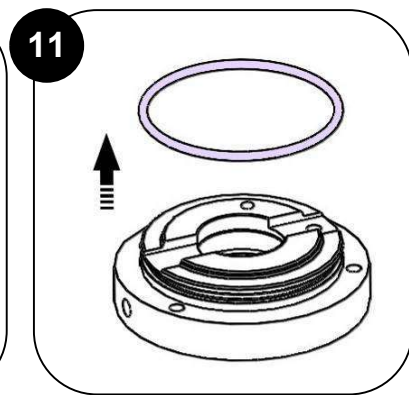
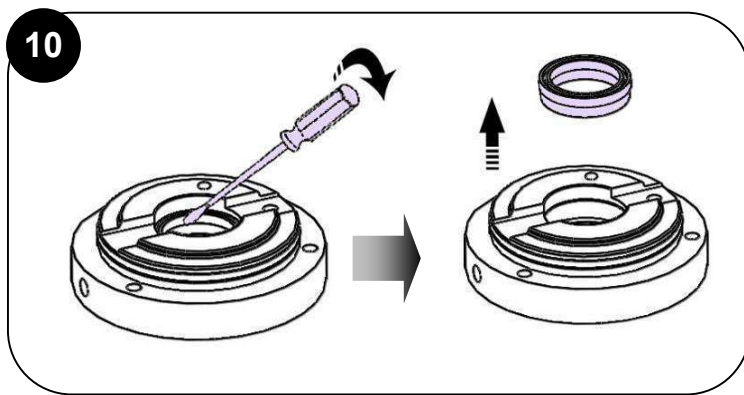
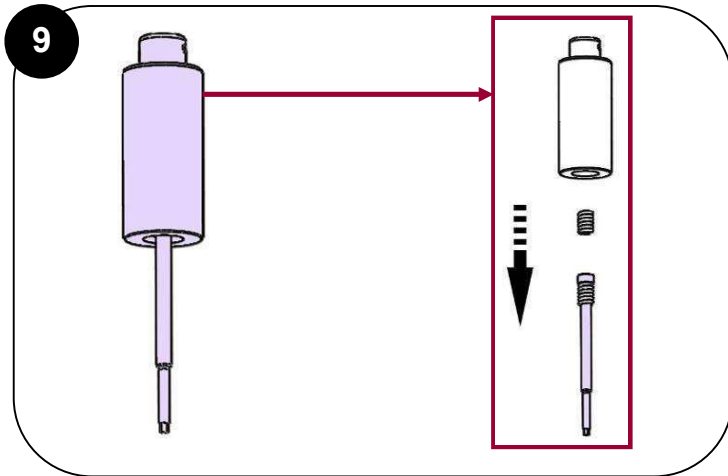
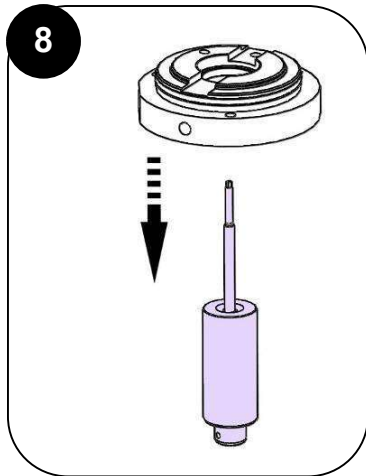

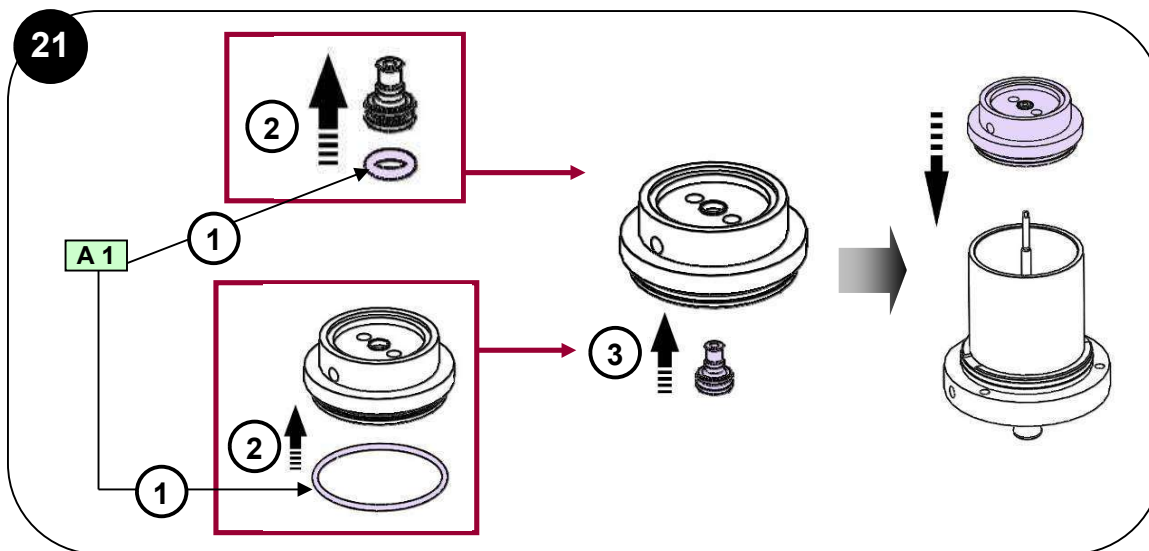
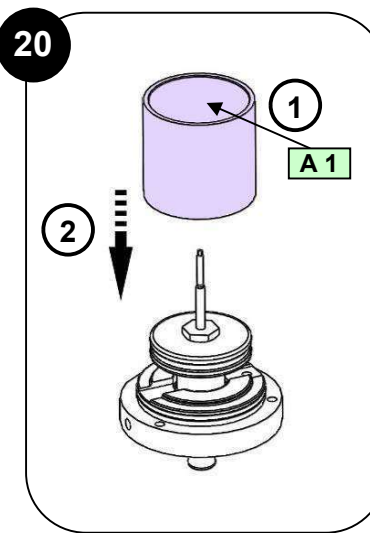
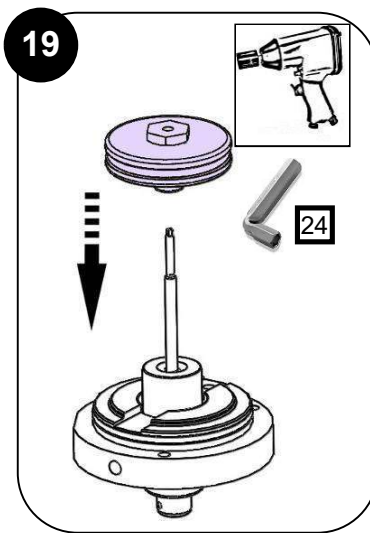
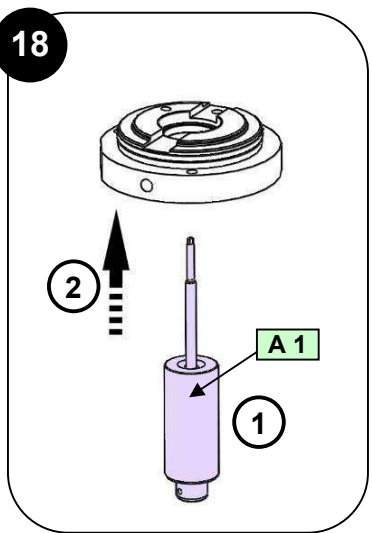
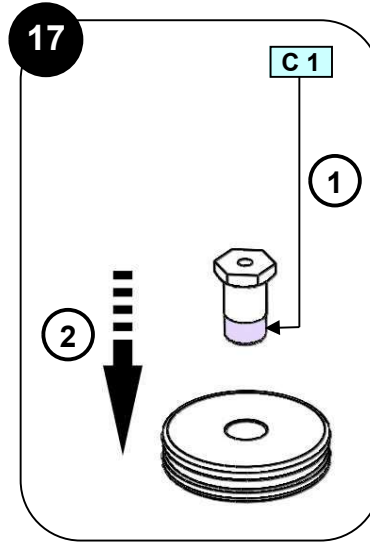
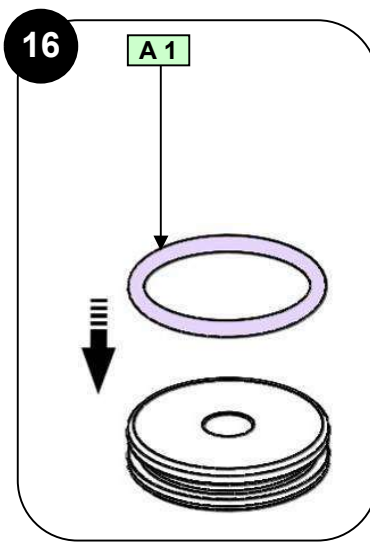
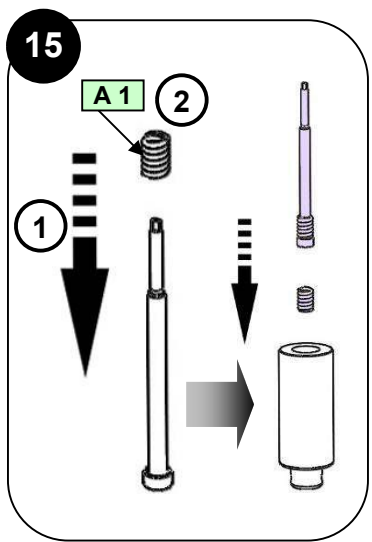

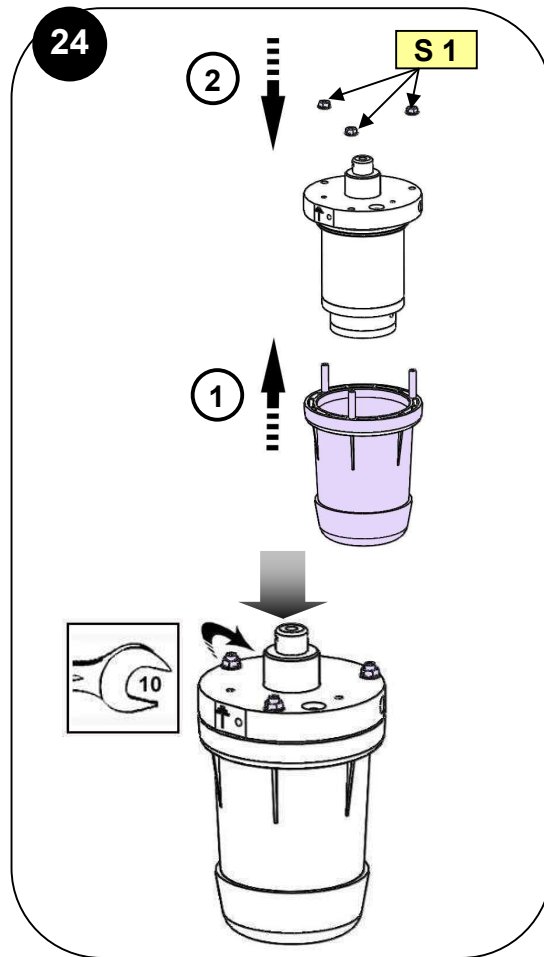
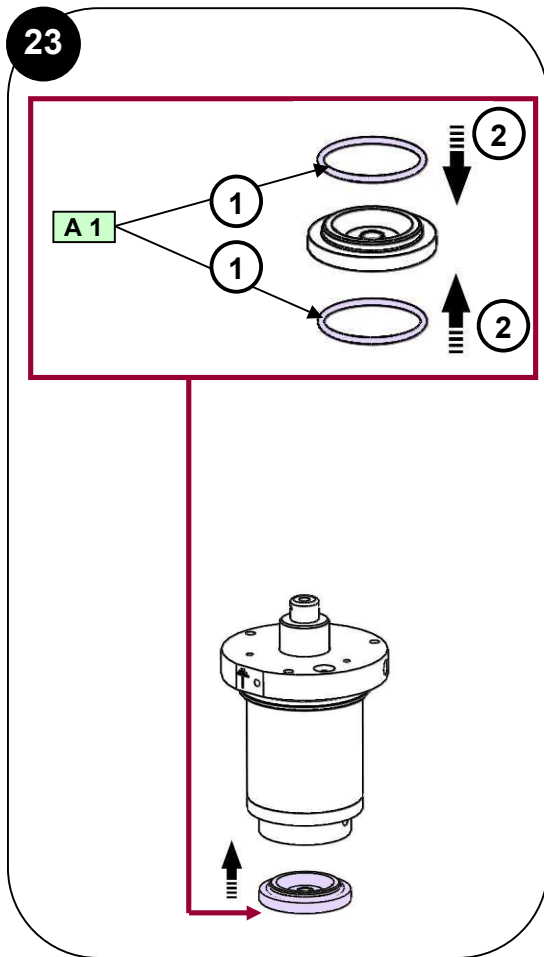
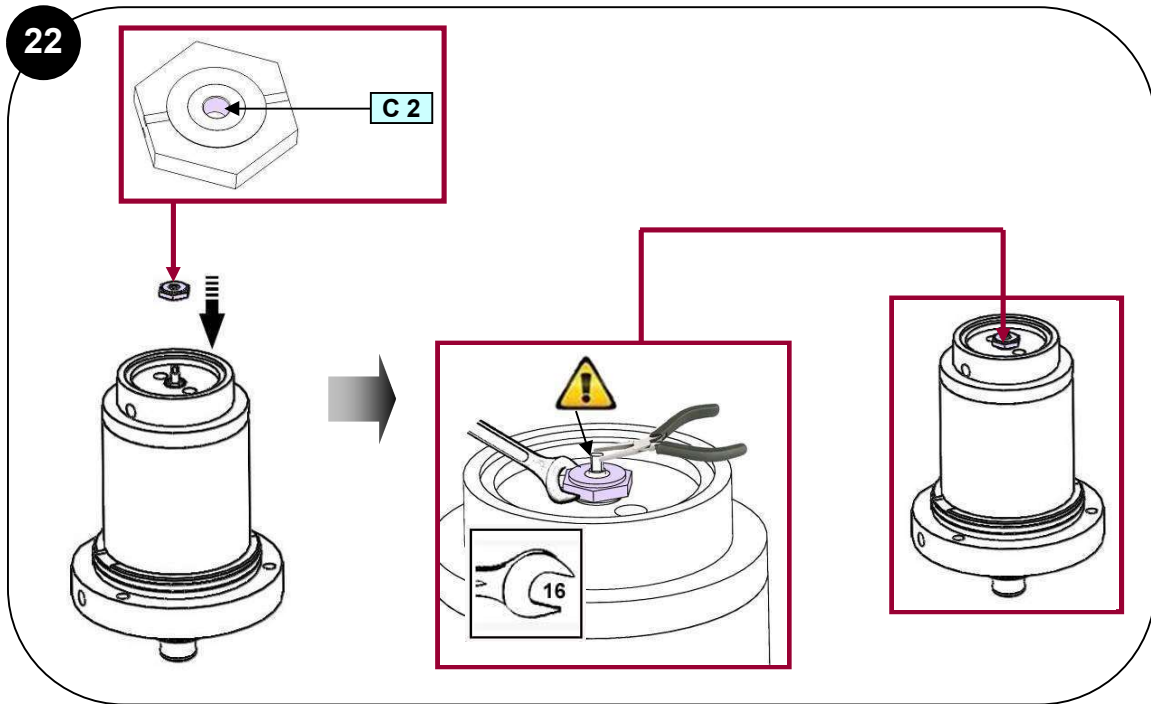

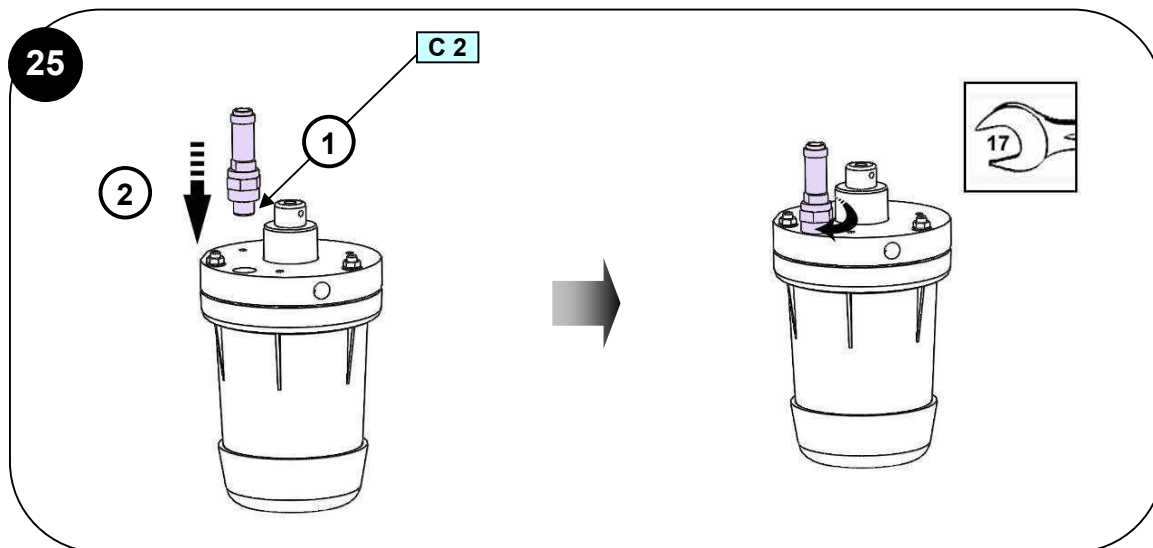

Des protecteurs (capot moteur, protecteur d'accouplement, carters,...) sont mis en place pour une utilisation sûre du matériel.

Le fabricant ne peut être tenu pour responsable en cas de dommages corporels ainsi que des pannes et / ou endommagement du matériel résultant de la destruction, de l'occultation ou du retrait total ou partiel des protecteurs.

/ Guards (air motor cover, coupling shields, housings ...) have been designed for safe use of the equipment. The manufacturer will not be held responsible for bodily injury or failure and / or damage to property due to removal or partial removal of the guards.

/ Schutzvorrichtungen an diesem Gerät, wie Motorhaube, Kupplungsschutz, Gehäuse, ggf. Erdungskabel, sowie weitere Vorrichtungen, wurden für eine sichere Benutzung dieses Gerätes entwickelt und angebracht. Der Hersteller lehnt jede Verantwortung für Körperschäden, Fehlfunktionen, Beschädigung der Geräte, und jegliche andere Fehler ab, die durch die ganze oder teilweise Entfernung, Modifikation oder unsachgemäße Handhabung der Schutzvorrichtungen oder anderen Geräteteilen entstehen.

/ Protectores (capó motor, protector de acoplamiento, cárteres,...) se colocan para una utilización segura del material. El fabricante no se hace responsable, en caso de daños y / o daños del material, resultantes de la destrucción, la ocultación o la retirada total o parcial de los protectores.

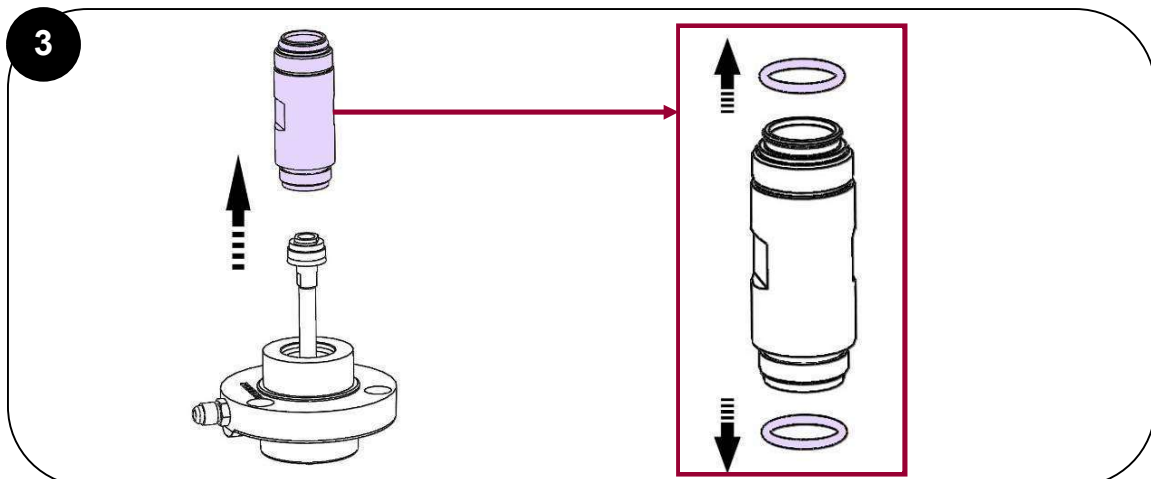
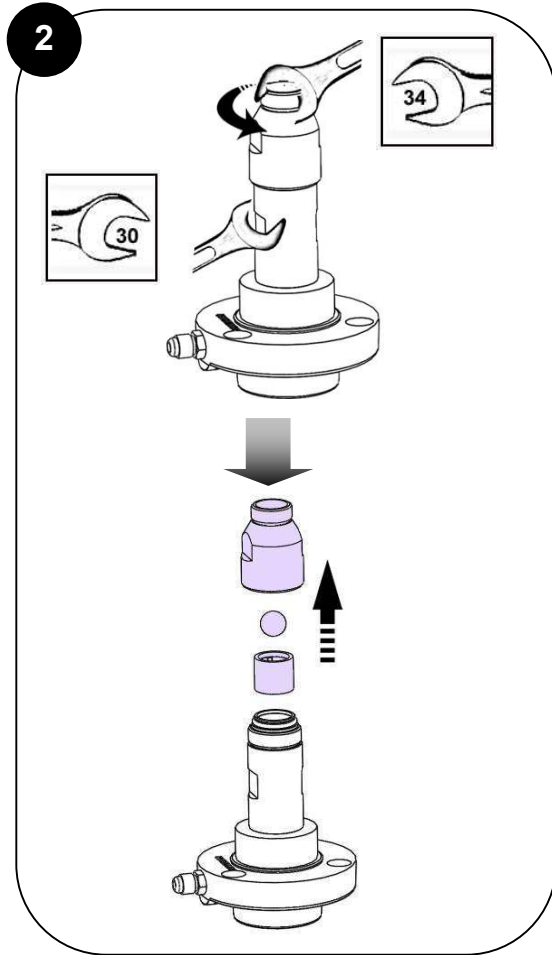
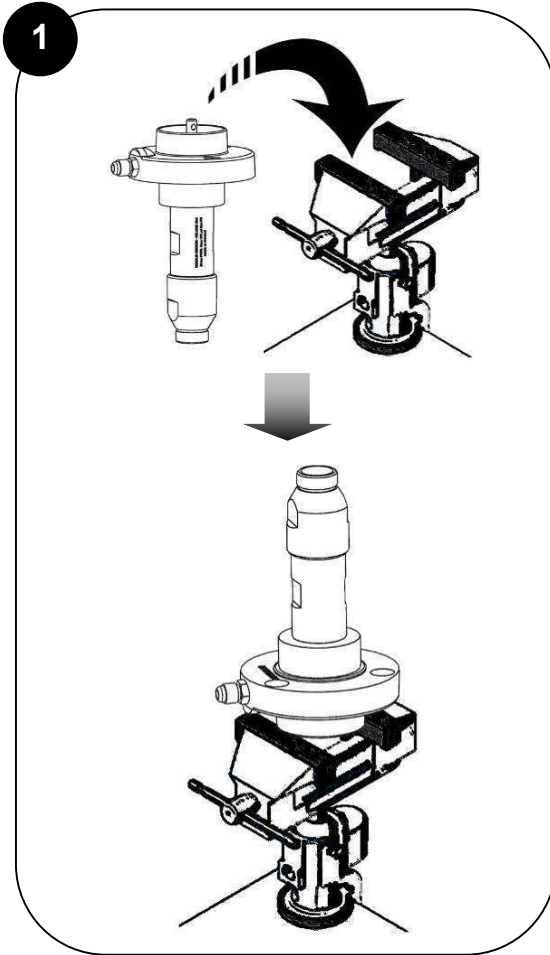
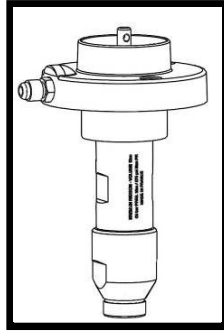

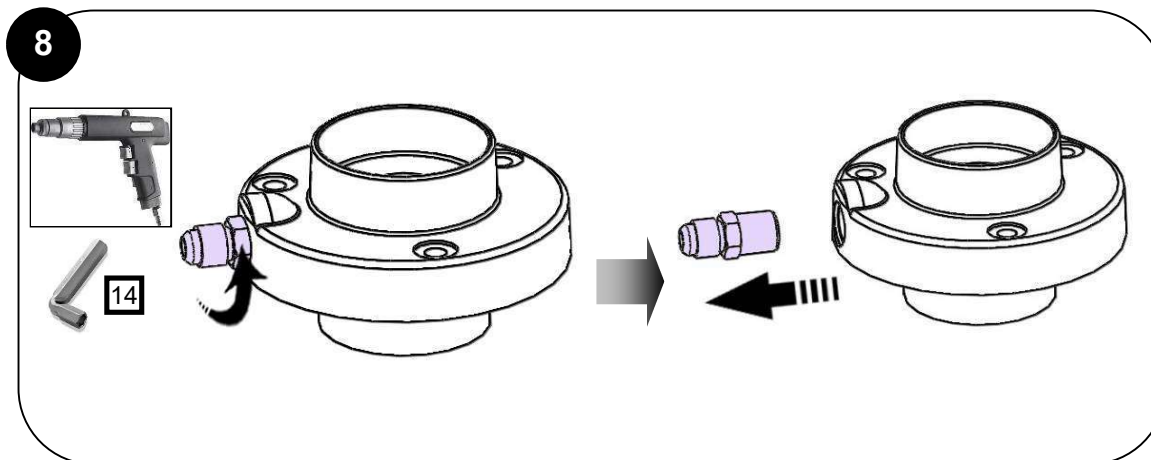
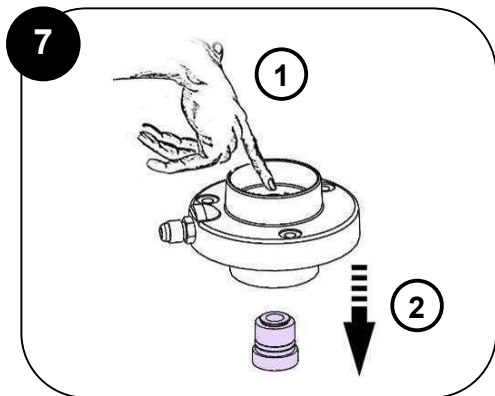
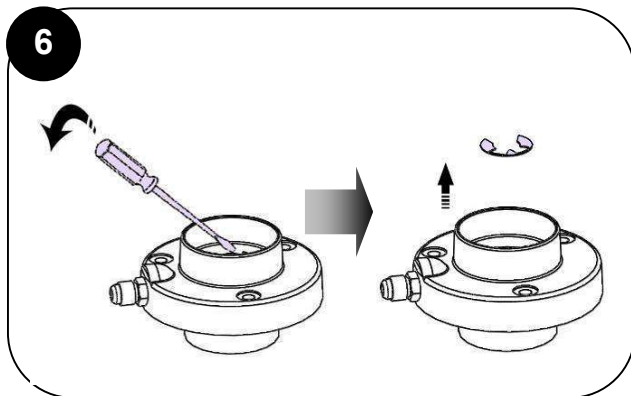
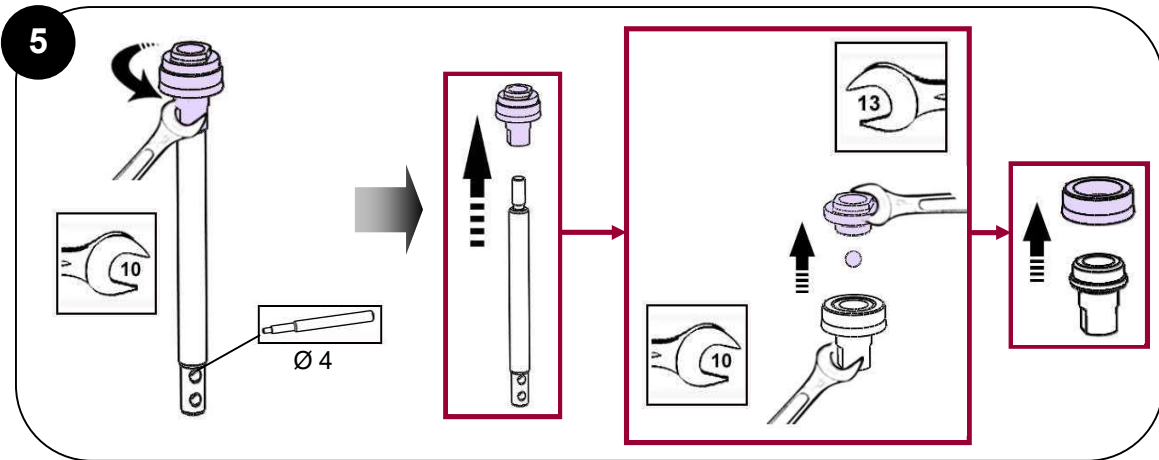
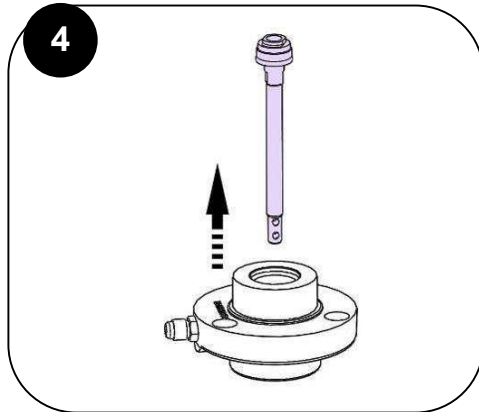

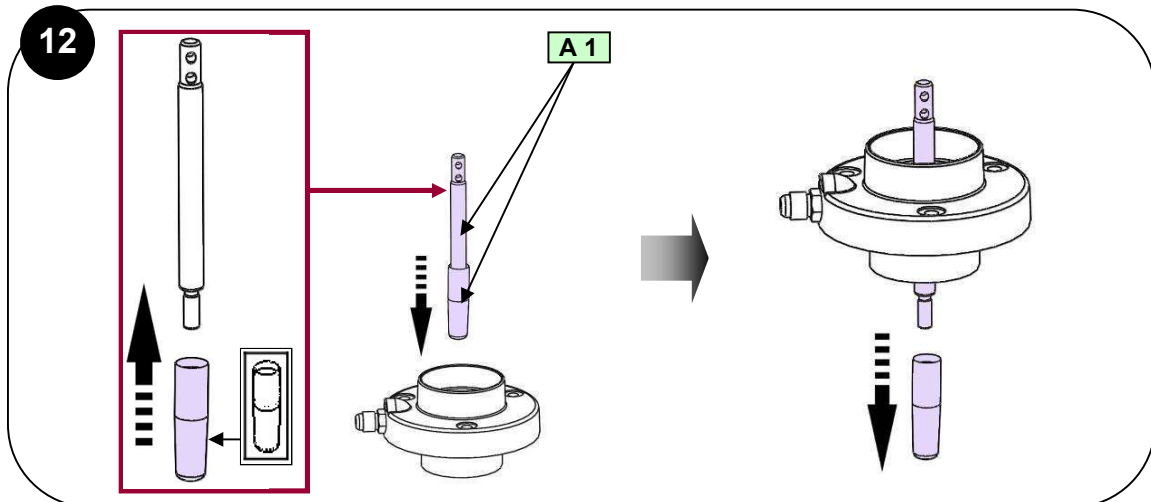
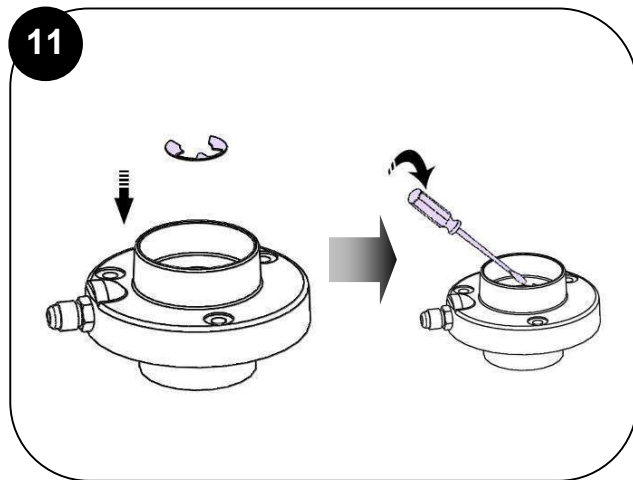
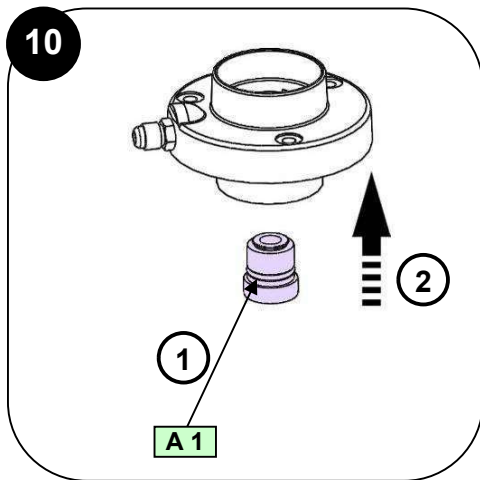
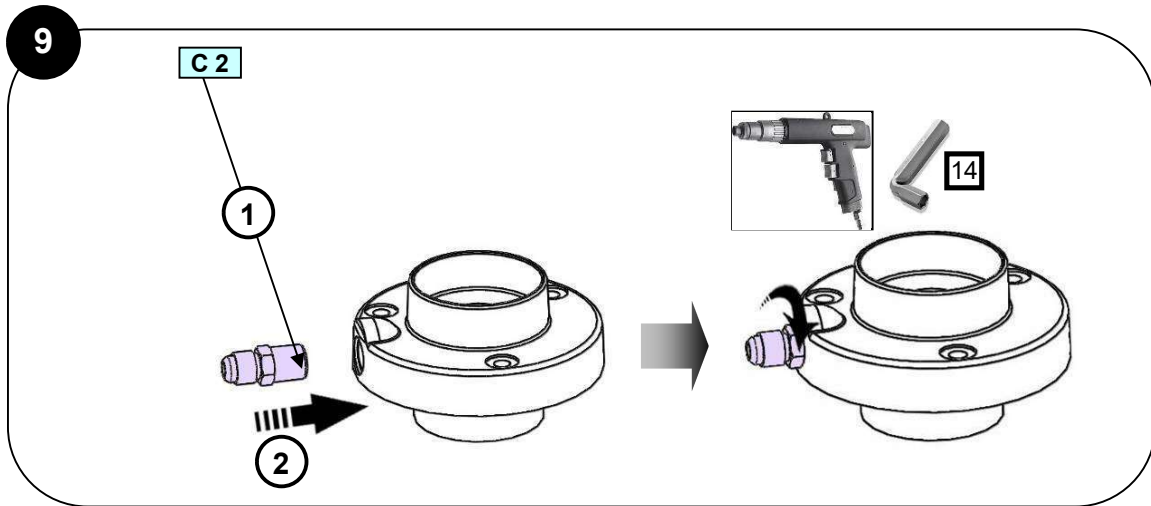

13

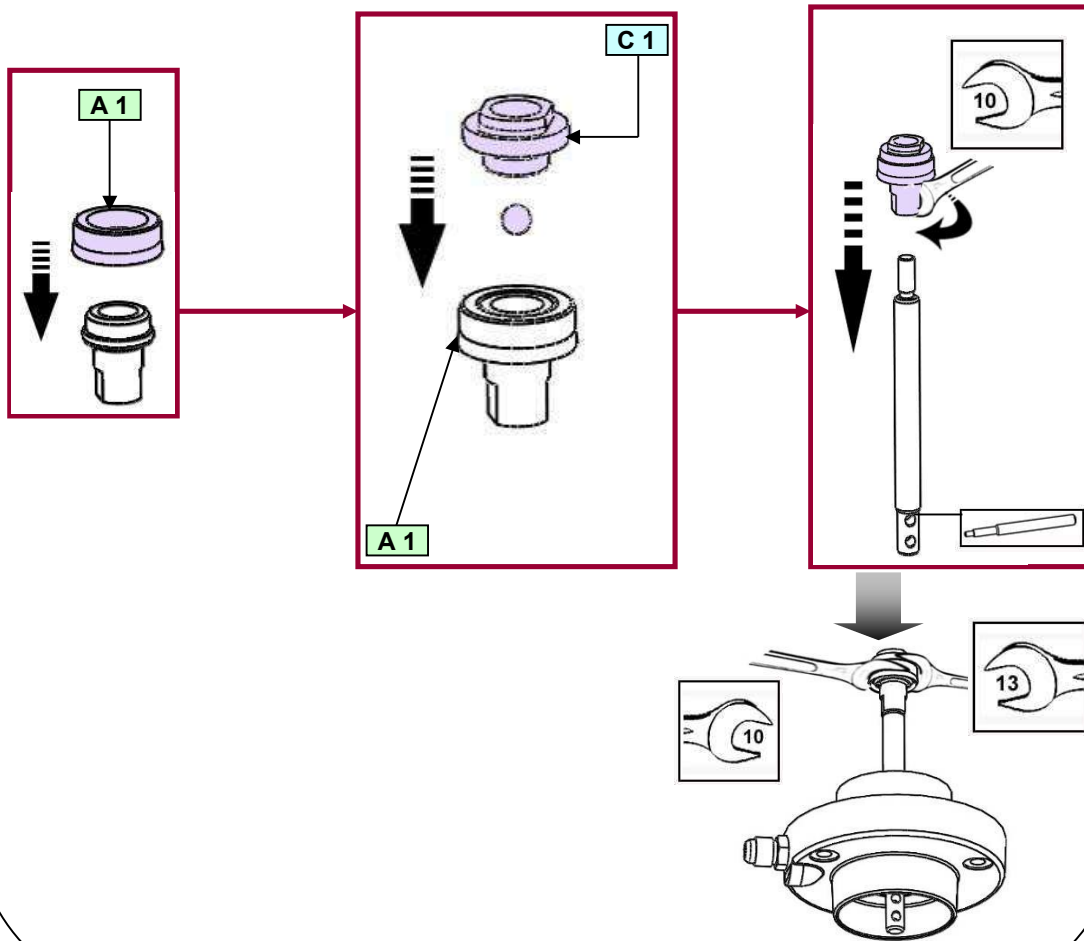

14

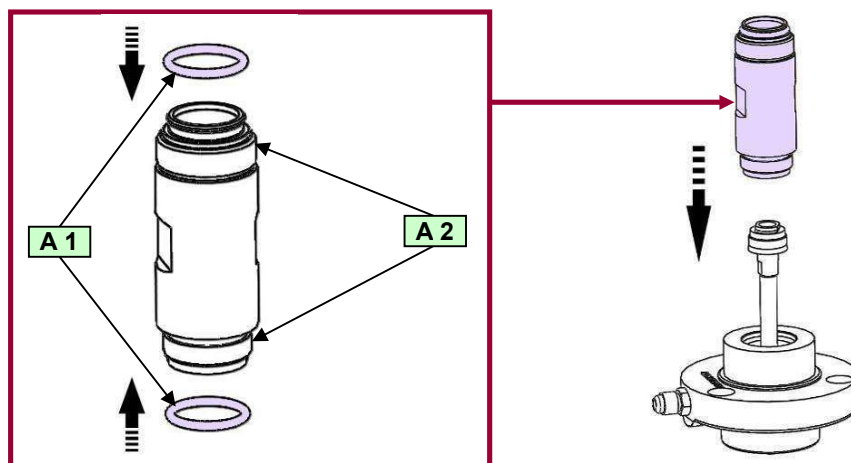

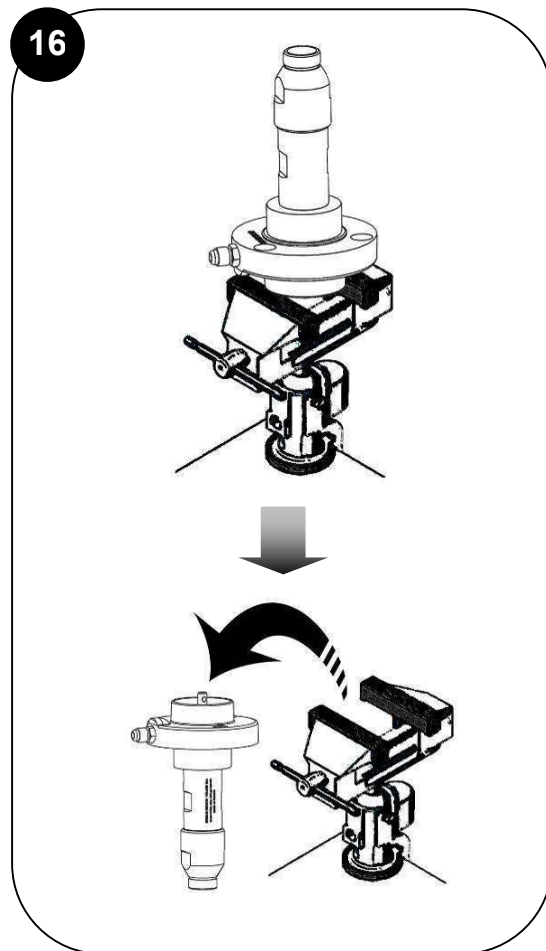
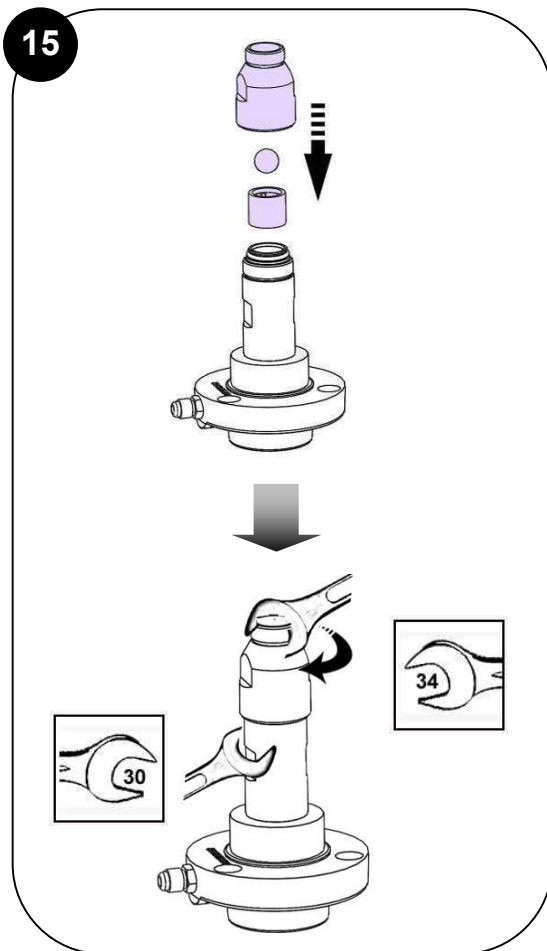

Des protecteurs (capot moteur, protecteur d'accouplement, carters,...) sont mis en place pour une utilisation sûre du matériel.

Le fabricant ne peut être tenu pour responsable en cas de dommages corporels ainsi que des pannes et / ou endommagement du matériel résultant de la destruction, de l'occultation ou du retrait total ou partiel des protecteurs.

/ Guards (air motor cover, coupling shields, housings ...) have been designed for safe use of the equipment. The manufacturer will not be held responsible for bodily injury or failure and / or damage to property due to removal or partial removal of the guards.

/ Schutzvorrichtungen an diesem Gerät, wie Motorhaube, Kupplungsschutz, Gehäuse, ggf. Erdungskabel, sowie weitere Vorrichtungen, wurden für eine sichere Benutzung dieses Gerätes entwickelt und angebracht. Der Hersteller lehnt jede Verantwortung für Körperschäden, Fehlfunktionen, Beschädigung der Geräte, und jegliche andere Fehler ab, die durch die ganze oder teilweise Entfernung, Modifikation oder unsachgemäße Handhabung der Schutzvorrichtungen oder anderen Geräteteilen entstehen.

/ Protectores (capó motor, protector de acoplamiento, cárteres,...) se colocan para una utilización segura del material. El fabricante no se hace responsable, en caso de daños y / o daños del material, resultantes de la destrucción, la ocultación o la retirada total o parcial de los protectores.

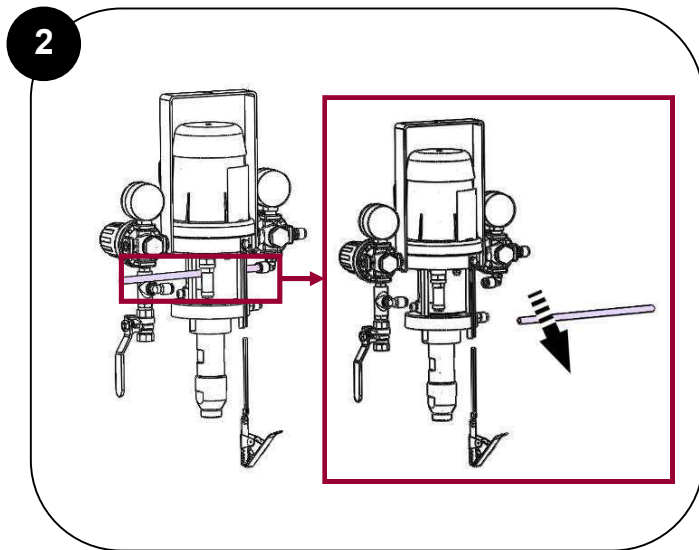
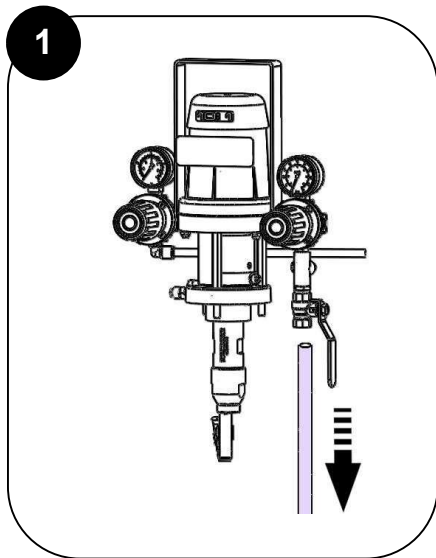
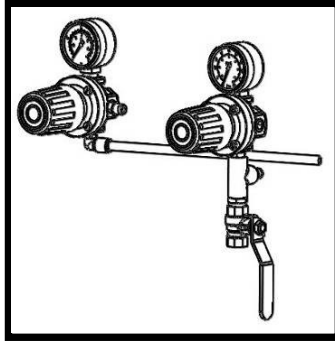

**Voir / Refer to
Siehe / Consultar
p. 23 → 27**



**Voir / Refer to
Siehe / Consultar
p. 28 → 30**

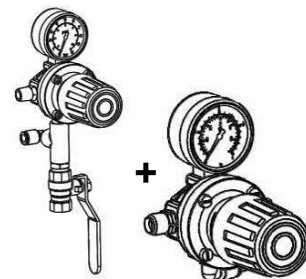

**Voir / Refer to
Siehe / Consultar
p. 31 → 32**

3

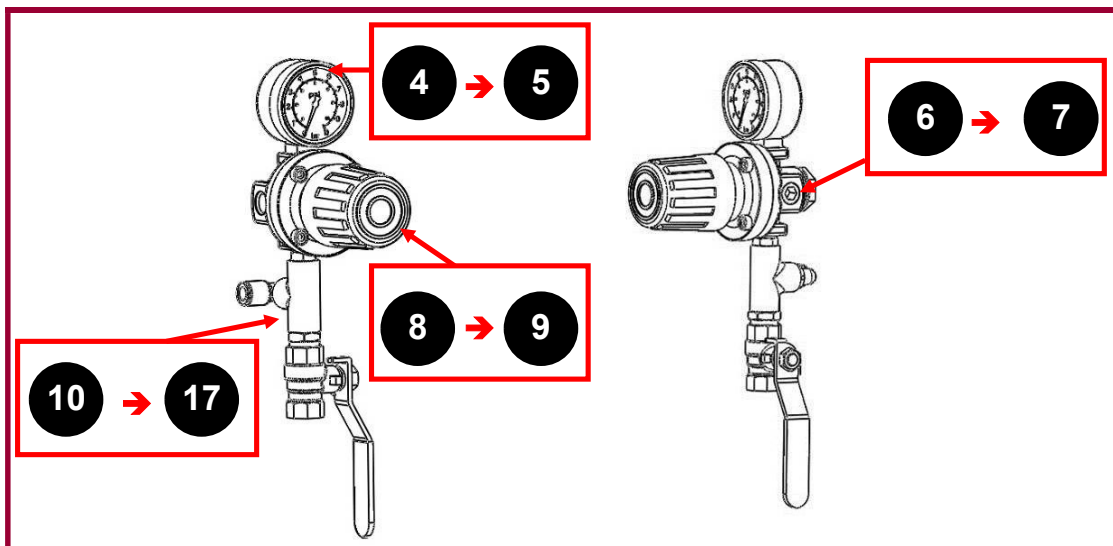
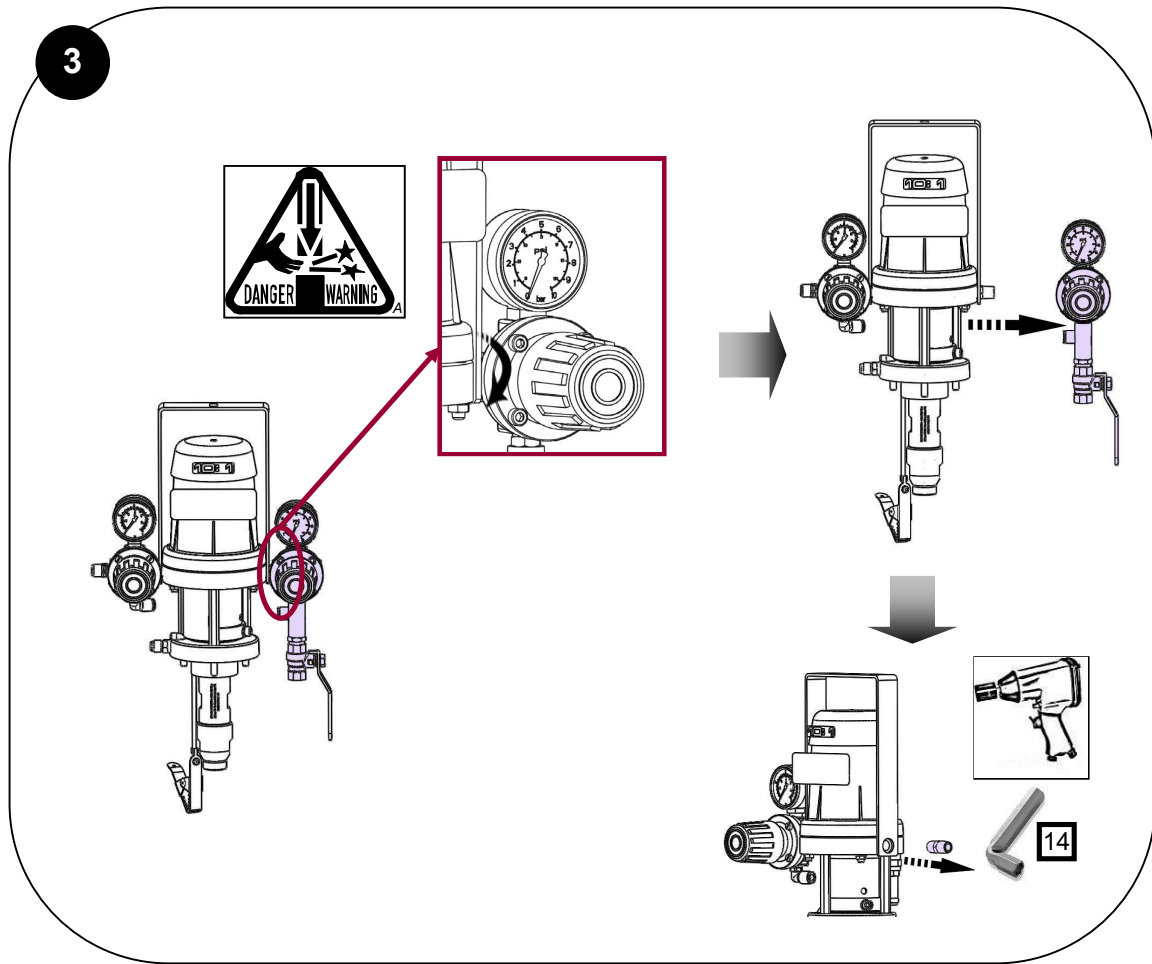

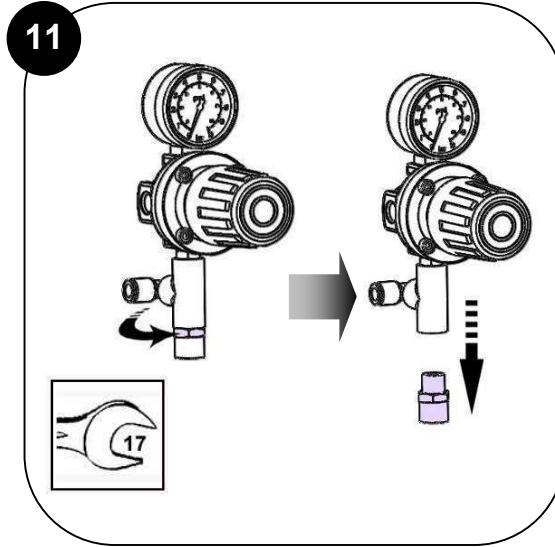
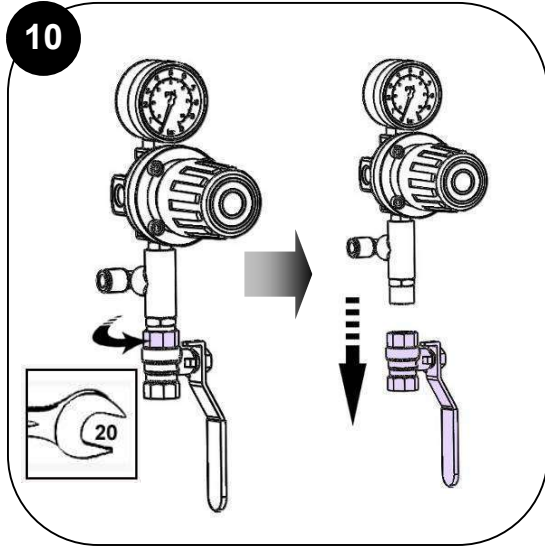
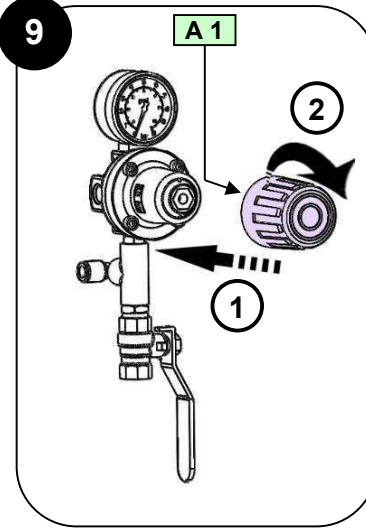
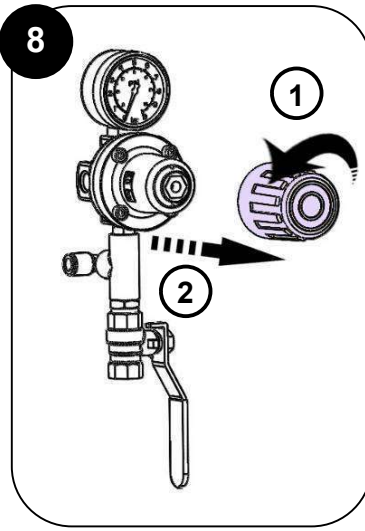
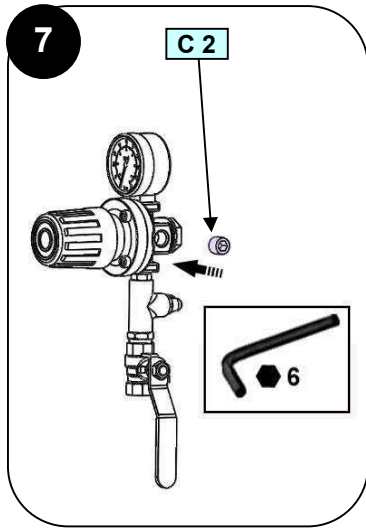
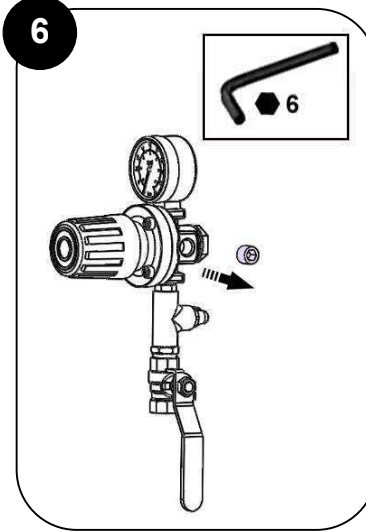
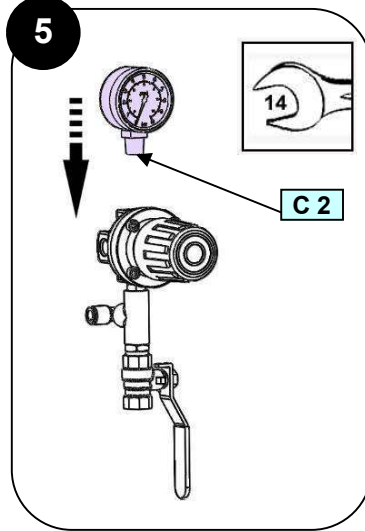
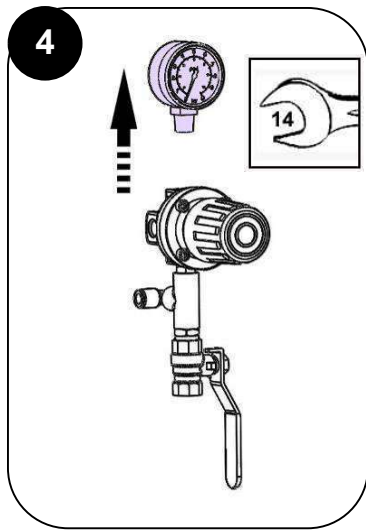

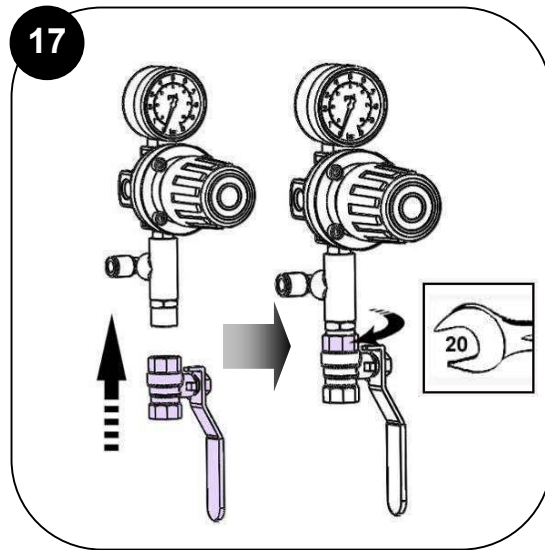
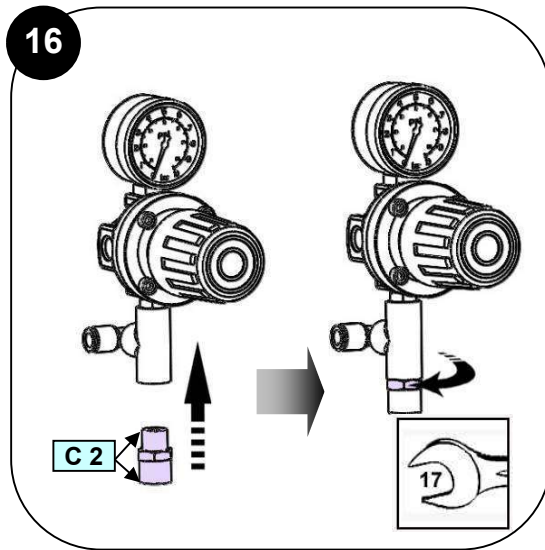
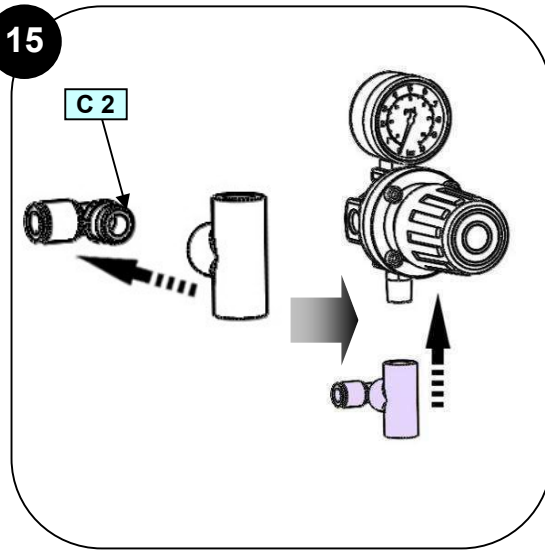
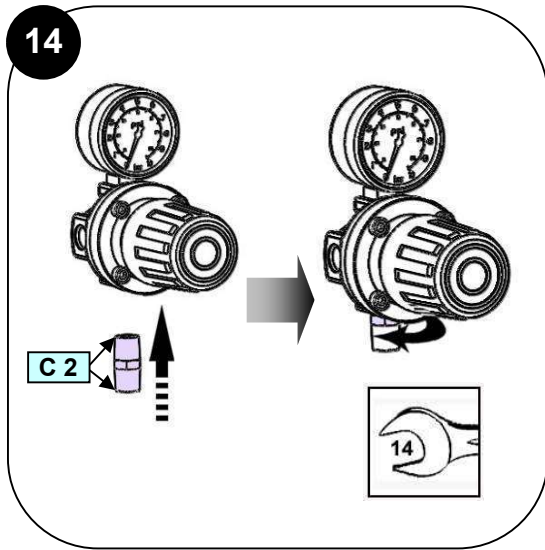
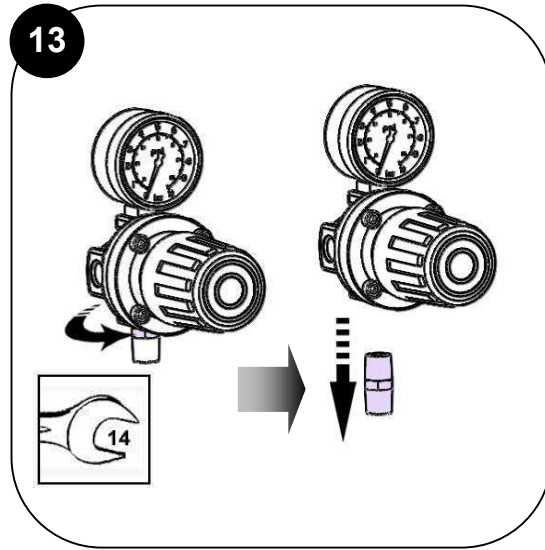
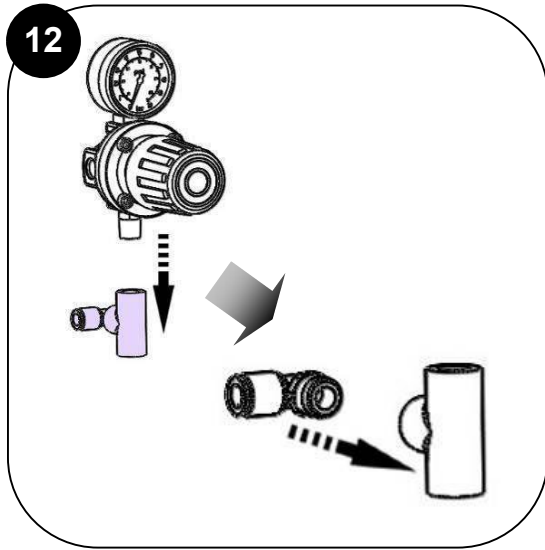

18

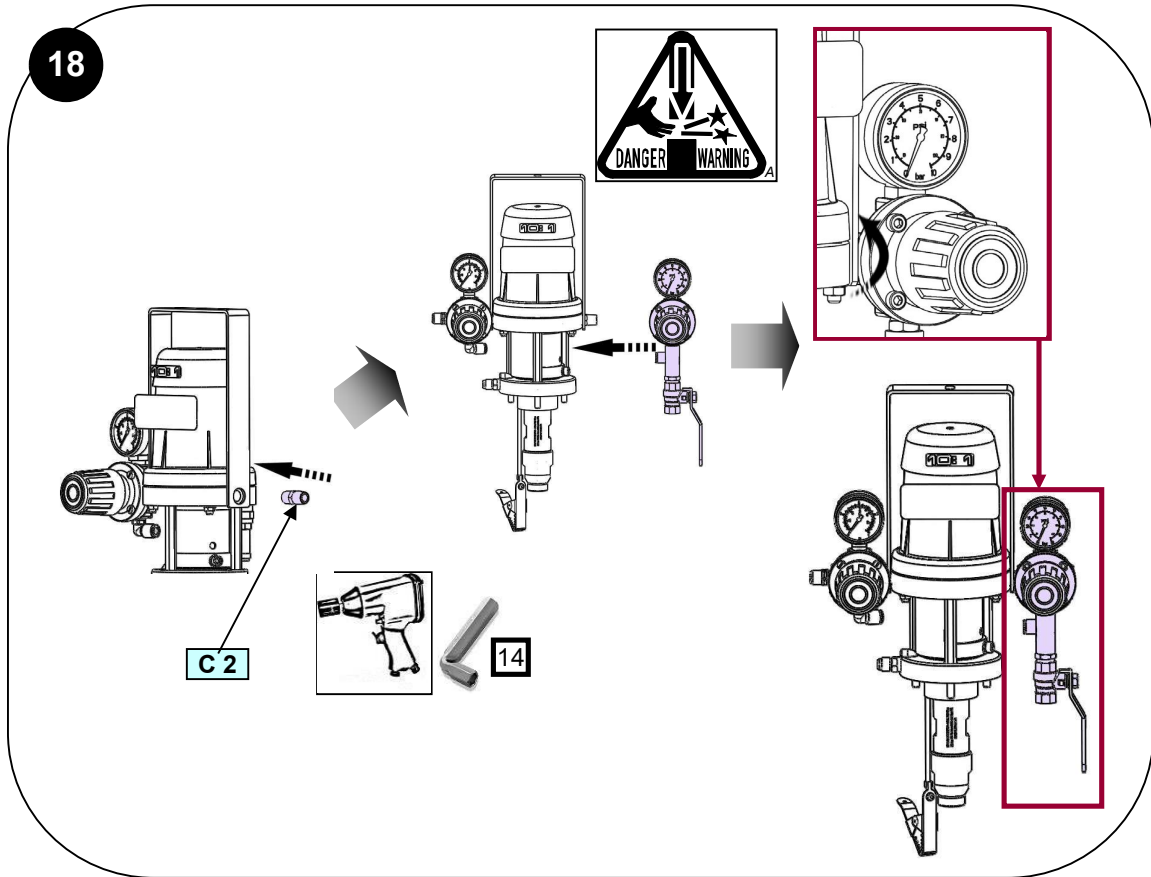

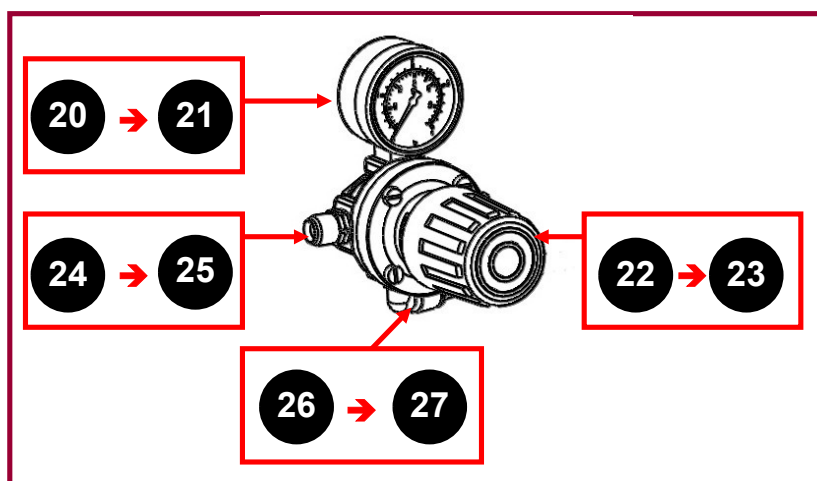
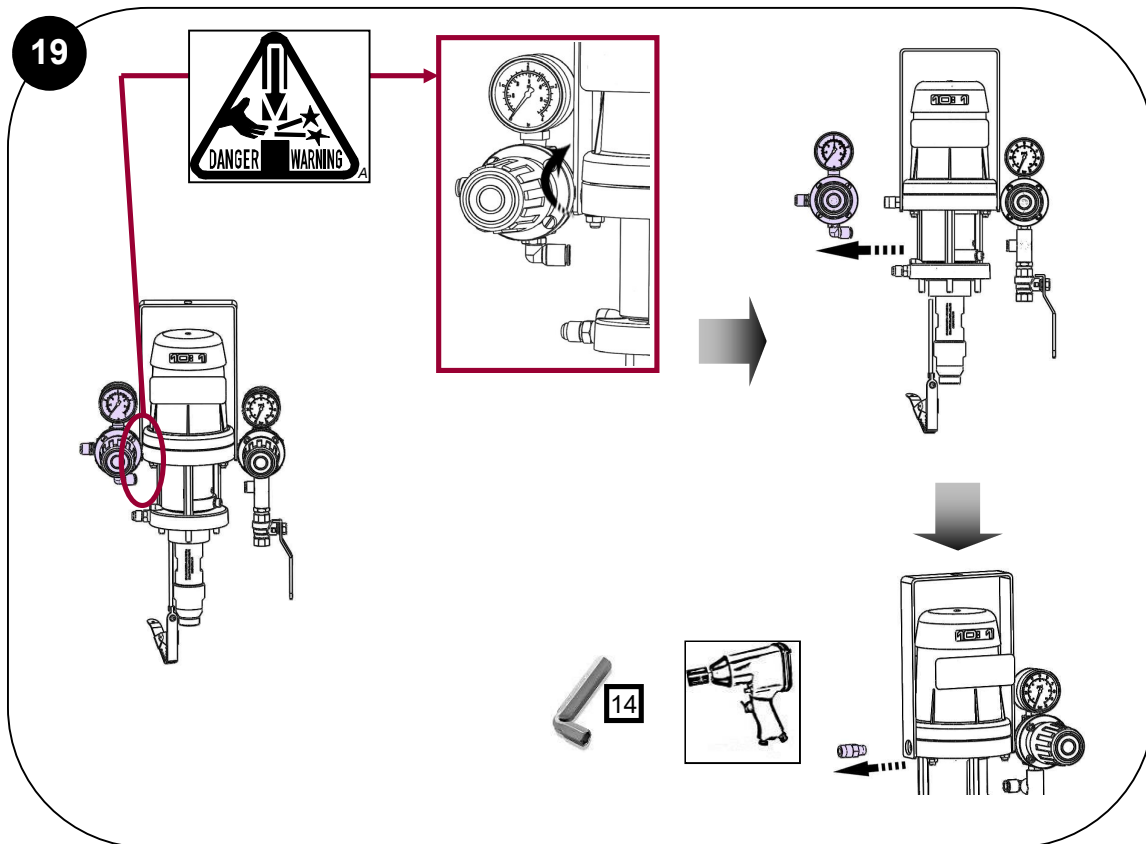

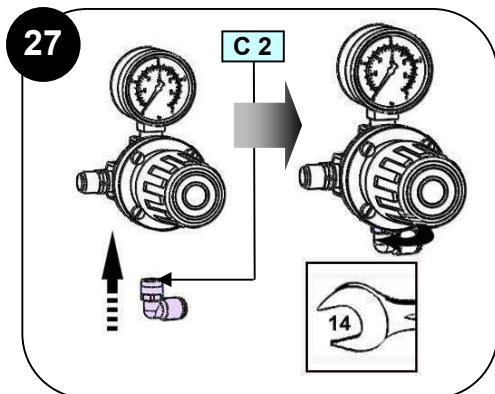
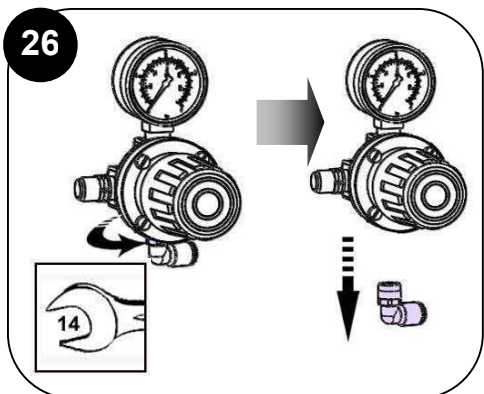
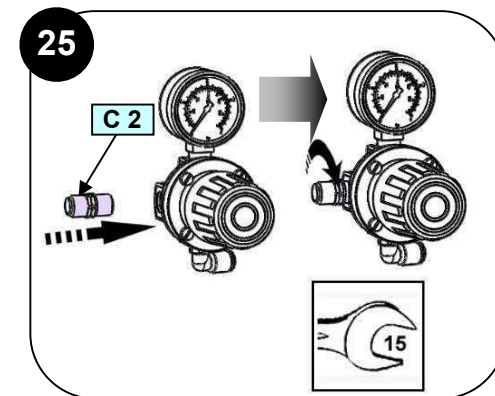
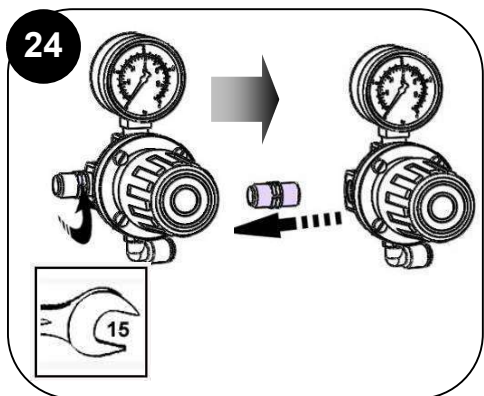
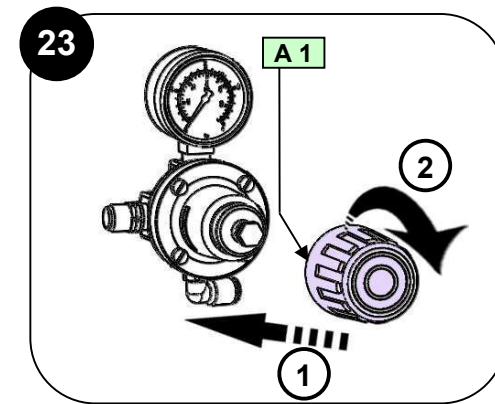
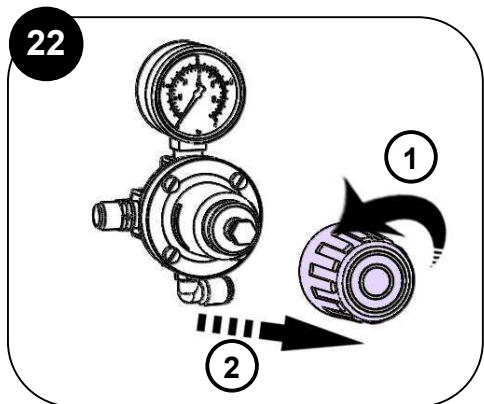
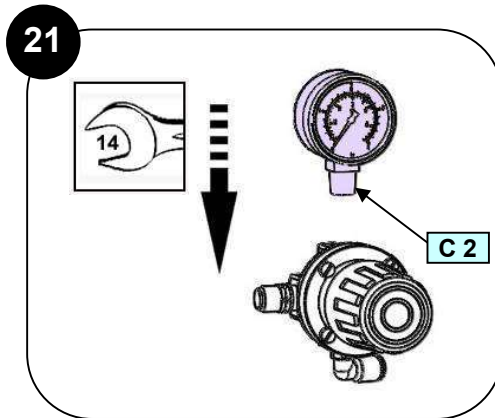
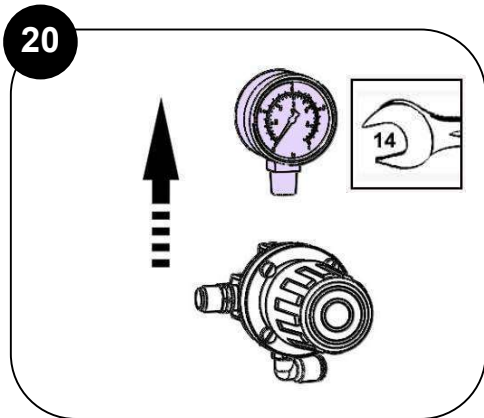

28

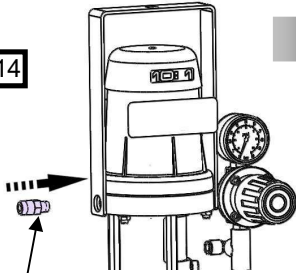
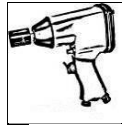

C 2

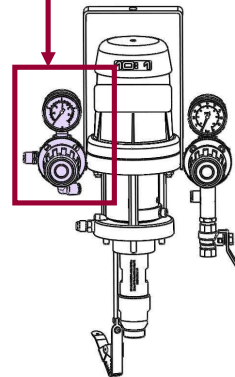
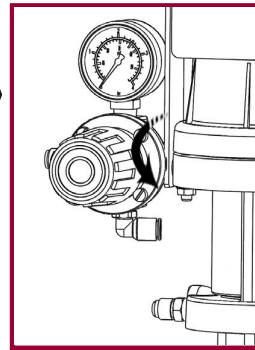
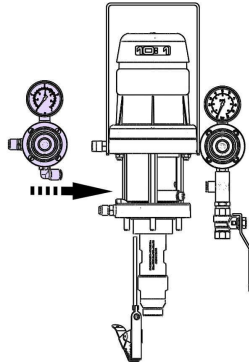

29

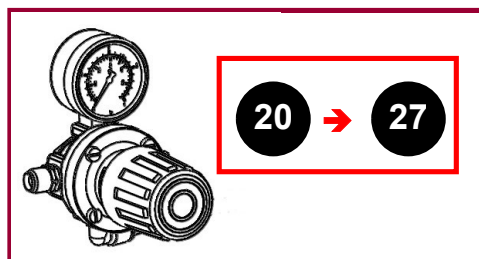
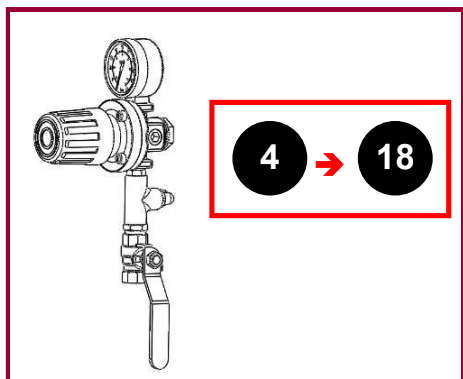
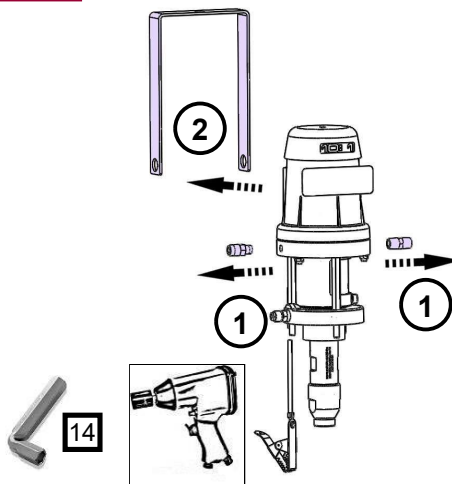
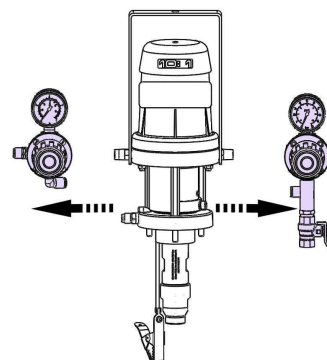
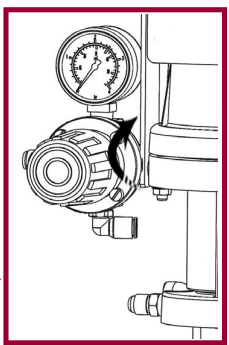
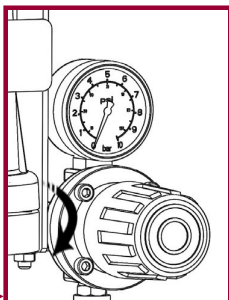
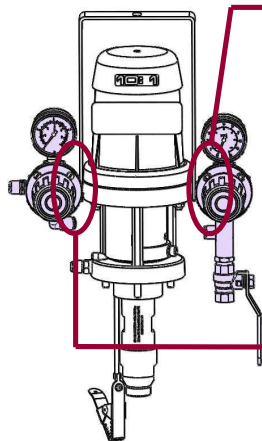

30

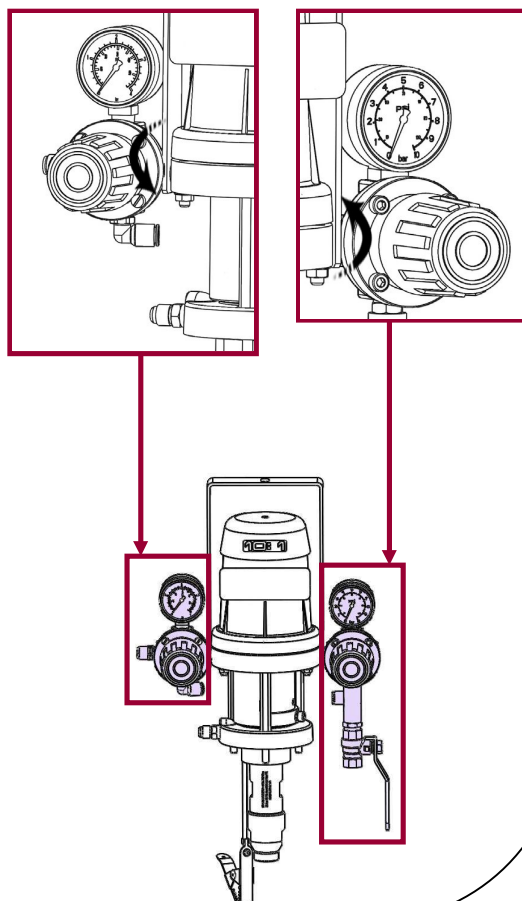
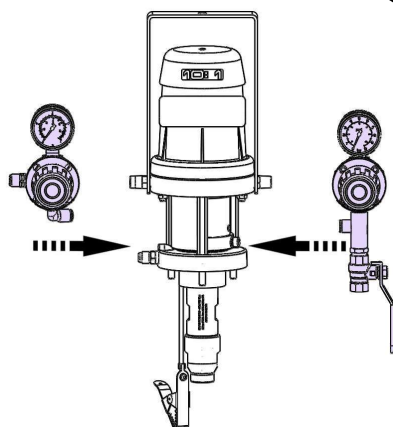
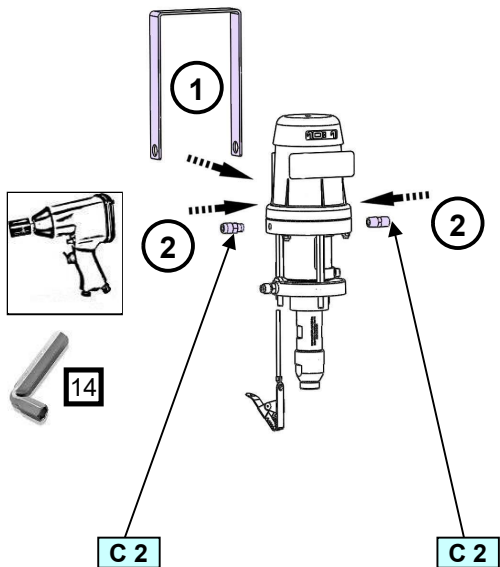

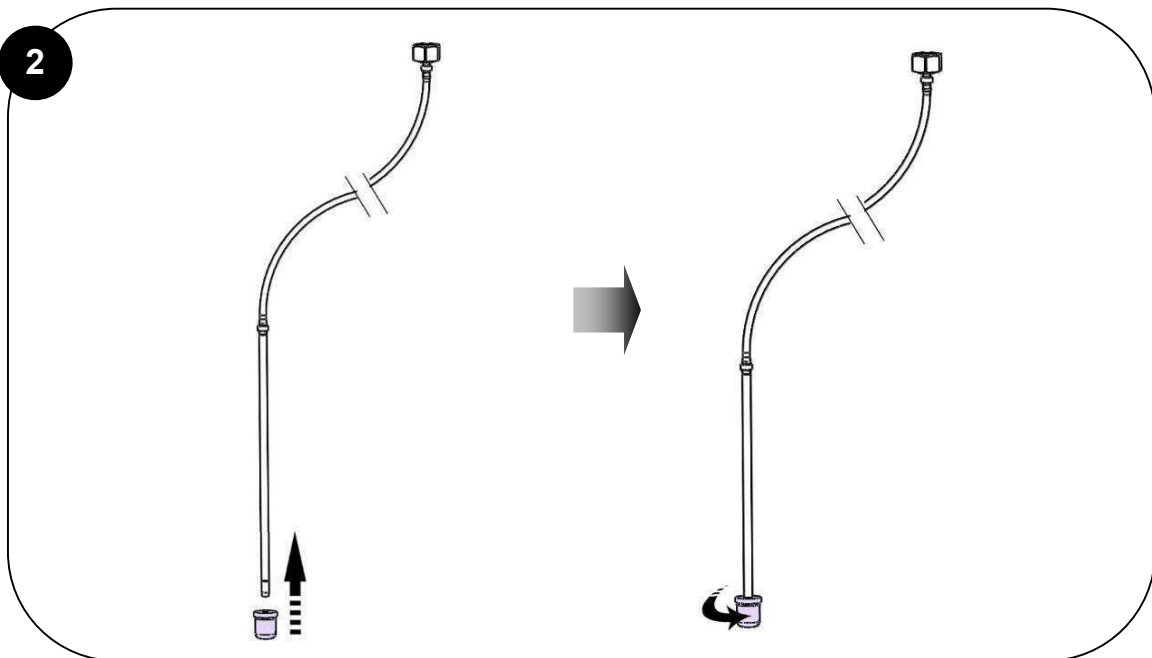
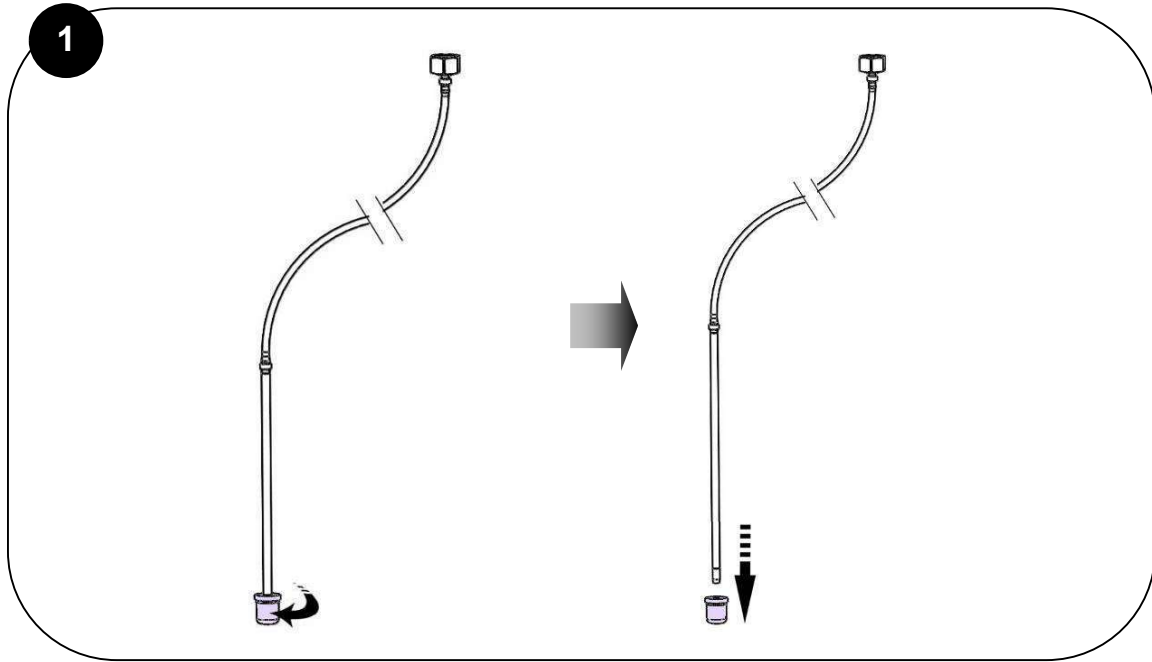
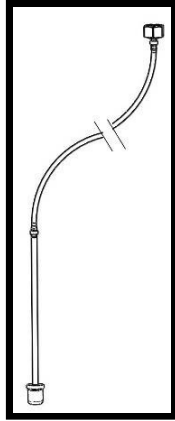

<p>Doc. 573.421.050 Date/Datum/Fecha :07/12/2020 Annule/Cancela/ Ersetzt/Anula : 13/11/19</p>	<p>Modif. / Änderung : #151 665 655 supprimé / canceled / annulliert / suprimido #144 855 700 → NC / NS</p>	<p>Pièces de rechange Spare parts list Ersatzteilliste Piezas de repuesto</p>
---	---	---

POMPE MURALE, modèle 10-C18	WALL MOUNTED PUMP, model 10-C18
PUMPE - WANDANLAGE, Modell 10-C18	BOMBA MURAL, tipo 10-C18

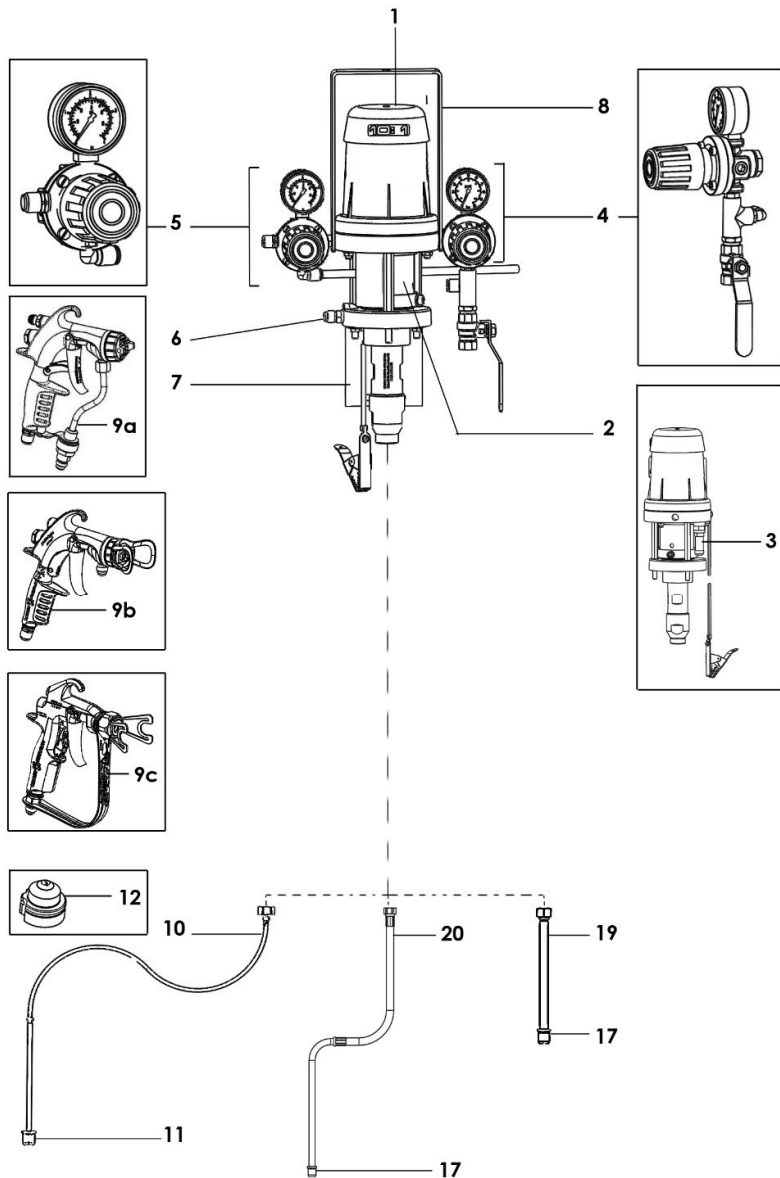
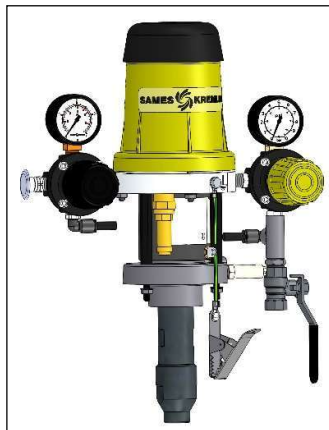

POMPE MURALE, modèle 10-C18 avec canne d'aspiration Ø 10 et pistolet (Clapet d'aspiration : M 26x125)	WALL MOUNTED PUMP, model 10-C18 with suction rod Ø 10 and gun (Suction valve : M 26x125)	#
WANDANLAGE, Modell 10-C18 mit Saugschlauch Ø 10 und Pistole (Ansaugventil: M 26x1,25 AG)	BOMBA MURAL, tipo 10-C18 con caña de aspiración Ø 10 y pistola (Válvula de aspiración : M 26x125)	151.665.720

Ind	#	Désignation	Description	Bezeichnung	Denominación	Qté
1	-	Pompe nue inox	Bare pump, stainless steel	Pumpe nackt, Edelstahl	Bomba sola de inox	1
*	144 855 600	▪ Moteur 340/2 (voir Doc. 573.419.050)	▪ Air motor, model 340/2 (refer to Doc. 573.419.050)	▪ Luftmotor , Modell 340/2 (siehe Dok. 573.419.050)	▪ Motor, tipo 340/2 (consultar Doc. 573.419.050)	1
*	NC / NS	▪ Hydraulique C-18 (Entrée produit M 26x125) (voir Doc.573.420.050)	▪ Fluid section, model C-18 (Material inlet M 26x125) (refer to Doc. 573.420.050)	▪ Hydraulikteil, Modell C-18 (Materialeingang M 26x1,25 AG) (siehe Dok. 573.420.050)	▪ Hidráulica, tipo C-18 (Entrada producto M 26x125) (consultar Doc. 573.420.050)	1
-	144 855 501	▪ Kit d'accouplement	▪ Coupling kit	▪ Kupplungskit	▪ Eje de acoplamiento	1
-	144 855 551	▪ Kit tirants et écrous	▪ Tie-rods and nuts kit	▪ Stehbolzen und Mutter	▪ Kit tirantes y tuercas	3
-	NC / NS	• Tirant	• Tie-rod, connecting	• Stehbolzen	• Tirantes	3
-	906 011 501	• Ecrou	• Nut	• Mutter	• Tuerca	3
2	044 855 010	▪ Carter de protection	▪ Protection housing	▪ Schutzgehäuse	▪ Cáster de protección	1
3	903 080 401	▪ Soupape de sécurité (6,5 bar)	▪ Relief-valve (6.5 bar / 94 psi)	▪ Sicherheitsventil (6,5 bar)	▪ Válvula de seguridad (6,5 bar)	1
4	151 665 658	Equipement d'air puissance	Power air supply	Luftausrüstung für Arbeitsluft	Equipo de aire potencia	1
5	151 665 659	Equipement d'air pulvérisation	Spraying air supply	Luftausrüstung für Zerstäuberluft	Equipo de aire pulverización	1
6	000 972 025	Raccord inox MM 1/4 NPT - 1/2 JIC (sortie produit)	Fitting, stainless steel double male, 1/4 NPT - 1/2 JIC (fluid outlet)	Doppelnippel, Edelstahl 1/4 NPT - 1/2 JIC (Materialausgang)	Racor de inox, MM 1/4 NPT - 1/2 JIC (salida producto)	1
7	051 660 002	Support de pompe	Wall mounting bracket	Wandhalterung	Soporte mural	1
-	144 910 129	Pochette de 4 vis, 4 écrous, 4 rondelles	Pack of 4 screws, 4 nuts, 4 washers	Satz à 4 Schrauben, 4 Scheiben, 4 Muttern	Bolsa de 4 tornillos, 4 tuercas, 4 arandelas	1
8	151 665 651	Poignée	Handle	Tragegriff	Empuñadura	1
9a	135 720 120	Pistolet Xcite 120 bar sans raccord tournant (voir Doc. 573.512.050)	Xcite gun, model 120 bar / 1740 psi without swivel fitting (refer to Doc. 573.512.050)	Pistole Xcite, 120 bar Ohne Drehgelenk (siehe Dok. 573.512.050)	Pistola Xcite 120 bar sin racor giratorio (consultar Doc. 573.512.050)	1
10	151 665 640	Canne d'aspiration Ø 10 inox avec crépine	Suction rod Ø 10 (stainless steel) with strainer	Saugschlauch Ø 10 mit Siebkorb	Caña de aspiración Ø 10 (inox) con piña	1
11	151 665 645	▪ Crépine	▪ Strainer	▪ Siebkorb	▪ Piña	1

POMPE MURALE, modèle 10-C18 sans canne, avec tuyaux et pistolet (Clapet d'aspiration : M 26x125)	WALL MOUNTED PUMP, model 10-C18 without suction rod, with hoses and gun (Suction valve : M 26x125)	#
WANDANLAGE, Modell 10-C18 ohne Saugschlauch, mit Schlauch und Pistole (Ansaugventil: M 26x1,25 AG)	BOMBA MURAL, tipo 10-C18 sin caña de aspiración, con tuberías y pistola (Válvula de aspiración : M 26x125)	151.665.730

Ind	#	Désignation	Description	Bezeichnung	Denominación	Qté
1	-	Pompe nue inox	Bare pump, stainless steel	Pumpe nackt, Edelstahl	Bomba sola de inox	1
*	144 855 600	▪ Moteur 340/2 (voir Doc. 573.419.050)	▪ Air motor, model 340/2 (refer to Doc. 573.419.050)	▪ Luftmotor , Modell 340/2 (siehe Dok. 573.419.050)	▪ Motor, tipo 340/2 (consultar Doc. 573.419.050)	1
*	NC / NS	▪ Hydraulique C-18 (Entrée produit M 26x125) (voir Doc.573.420.050)	▪ Fluid section, model C-18 (Material inlet M 26x125) (refer to Doc. 573.420.050)	▪ Hydraulikteil, Modell C-18 (Materialeingang M 26x1,25 AG) (siehe Dok. 573.420.050)	▪ Hidráulica, tipo C-18 (Entrada producto M 26x125) (consultar Doc. 573.420.050)	1
-	144 855 501	▪ Kit d'accouplement	▪ Coupling kit	▪ Kupplungskit	▪ Eje de acoplamiento	1
-	144 855 551	▪ Kit tirants et écrous	▪ Tie-rods and nuts kit	▪ Stehbolzen und Mutter	▪ Kit tirantes y tuercas	3
-	NC / NS	• Tirant	• Tie-rod, connecting	• Stehbolzen	• Tirantes	3
-	906 011 501	• Ecrou	• Nut	• Mutter	• Tuerca	3
2	044 855 010	▪ Carter de protection	▪ Protection housing	▪ Schutzgehäuse	▪ Cártier de protección	1
3	903 080 401	▪ Soupape de sécurité (6,5 bar)	▪ Relief-valve (6.5 bar / 94 psi)	▪ Sicherheitsventil (6,5 bar)	▪ Válvula de seguridad (6,5 bar)	1
4	151 665 658	Equipement d'air puissance	Power air supply	Luftausrüstung für Arbeitsluft	Equipo de aire potencia	1
5	151 665 659	Equipement d'air pulvérisation	Spraying air supply	Luftausrüstung für Zerstäuberluft	Equipo de aire pulverización	1
6	000 972 025	Raccord inox MM 1/4 NPT - 1/2 JIC (sortie produit)	Fitting, stainless steel double male, 1/4 NPT - 1/2 JIC (fluid outlet)	Doppelnippel, Edelstahl 1/4 NPT - 1/2 JIC (Materialausgang)	Racor de inox, MM 1/4 NPT - 1/2 JIC (salida producto)	1
7	051 660 002	Support de pompe	Wall mounting bracket	Wandhalterung	Soporte mural	1
-	144 910 129	Pochette de 4 vis, 4 écrous, 4 rondelles	Pack of 4 screws, 4 nuts, 4 washers	Satz à 4 Schrauben, 4 Scheiben, 4 Muttern	Bolsa de 4 tornillos, 4 tuercas, 4 arandelas	1
8	151 665 651	Poignée	Handle	Tragegriff	Empuñadura	1
9a	135 720 120	Pistolet Xcite 120 bar sans raccord tournant (voir Doc. 573.512.050)	Xcite gun, model 120 bar / 1740 psi without swivel fitting (refer to Doc. 573.512.050)	Pistole Xcite, 120 bar Ohne Drehgelenk (siehe Dok. 573.512.050)	Pistola Xcite 120 bar sin racor giratorio (consultar Doc. 573.512.050)	1
*12	134 506 094	Buse Airmix® 06-094 (avec porte-insert inox)	Airmix® tip, model 06-094 (with stainless steel insert- holder)	Airmix® Düse 06-094 (mit Edelstahlfassung)	Boquilla Airmix®, tipo 06-094 (con porta in- serto de inox)	1

Ind	#	Désignation	Description	Bezeichnung	Denominación	Qté
-	050 382 114	Tuyau air (Ø 7x13 mm - Lg. 7,5 m - F 1/4 NPS)	Air hose (Ø 7x13 mm - 7,5 m / 24.6 ft length - F 1/4 NPS)	Luftschlauch (Ø 7x13mm - Länge 7,5m - IG 1/4 NPS)	Tubería de aire (Ø 7x13 mm - Longitud 7,5m - H 1/4 NPS)	1
-	050 450 855	Tuyau AIRMIX® (Ø 4,8 mm - Lg. 6 m - 120 bar)	AIRMIX® hose (Ø 4,8 mm / 3/16" - 6 m / 19,7 ft length - 120 bar / 1740 psi)	AIRMIX® - Schlauch (Ø 4,8 mm - Länge 6 m - 120 bar)	Tubería AIRMIX® (Ø 4,8 mm - Longitud 6 m - 120 bar)	1
-	129 270 087	Enveloppe de protection des tuyaux (Lg. 10 m)	Protective hose sleeving (10 m / 33 ft long)	Schutzhülle für Schlauch (Länge 10 m)	Funda de protección de las tuberías (10 m de largo)	1
13	151 665 705	Trépied (voir Doc. 578.187.110)	Tripod (refer to Doc. 578.187.110)	Dreibein (siehe Dok. 578.187.110)	Trípode (consultar Doc. 578.187.110)	1
10	151 665 640	Canne d'aspiration Ø 10 inox avec crépine	Suction rod Ø 10 (stainless steel) with strainer	Saugschlauch Ø 10 mit Siebkorb	Caña de aspiración Ø 10 (inox) con piña	1
11	151 665 645	▪ Crépine	▪ Strainer	▪ Siebkorb	▪ Piña	1

OPTIONS - ON REQUEST - OPTIONEN - OPCIONES

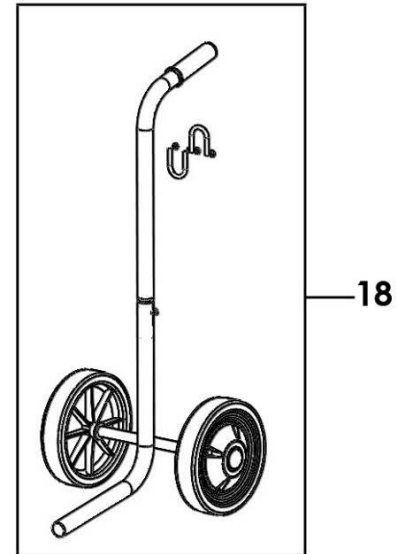
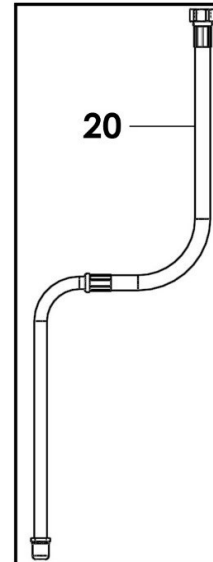
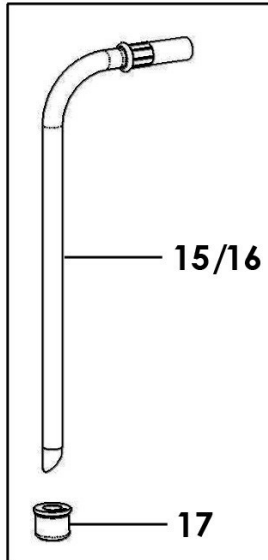
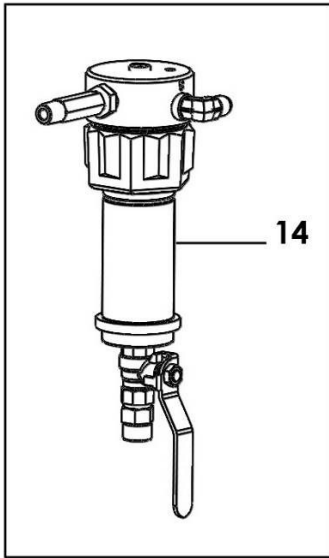

Ind	#	Désignation	Description	Bezeichnung	Denominación	Qté
14	155 580 510	Filtre produit 3/8" (voir Doc. 573.347.050)	Fluid filter, model 3/8" (refer to Doc. 573.347.050)	Materialfilter 3/8" (siehe Dok. 573.347.050)	Filtro producto, tipo 3/8" (consultar Doc. 573.347.050)	1
15	149 596 050	Canne d'aspiration Ø 16 (Lg. 0,57m)	Suction rod Ø 16 (Length : 0.57m)	Saugschlauch Ø 16 (Rohrlänge: 0,57m)	Caña de aspiración Ø 16 (Longitud : 0,57)	1
16	149 596 060	Canne d'aspiration inox Ø 16 (Lg. 1m)	Suction rod, stainless steel, Ø 16 (Length : 1m)	Saugschlauch, Edelstahl, Ø 16 (Rohrlänge: 1m)	Caña de aspiración de inox Ø 16 (Longitud : 1m)	1
17	149 596 052	Crépine Ø 16	Strainer Ø 16	Siebkorb Ø 16	Piña Ø 16	1
18	051 730 110	Chariot (1 bras) (voir Doc. 578.064.110)	Cart (1 arm) (refer to Doc. 578.064.110)	Fahrgestell (1 Arm) (siehe Dok. 578.064.110)	Carretilla (1 brazo) (consultar Doc. 578.064.110)	1
20	149 596 080	Canne d'aspiration raccourcie Ø 16 (Lg. 0,44m)	Short suction rod Ø 16 (Length : 0.44m)	Saugschlauch mit verkürztem Saugrohr Ø 16 (Rohrlänge: 0,44m)	Caña de aspiración corta Ø 16 (Longitud : 0,44m)	1

ACCESSOIRES - ACCESSORIES - ZUBEHÖR - ACCESORIOS

Ind	#	Désignation	Description	Bezeichnung	Denominación	Qté
-	149 990 020	Flacon de lubrifiant T (125 ml)	T lubricant (125 ml / 4.4 oz)	Spülmittel T (125 ml)	Botella de lubricante T (125 ml)	1

* Pièces de maintenance préconisées.

* Preceding the index number denotes a suggested spare part.

* Bezeichnete Teile sind empfohlene Ersatzteile.

* Piezas de mantenimiento preventivas.

N C : Non commercialisé.

N S : Denotes parts are not serviceable.

N S : Bezeichnete Teile gibt es nicht einzeln, sondern nur komplett .

N S : no suministrado.

Doc. 573.419.050 Date/Datum/Fecha : 19/09/19 Annule/Cancel/ Ersetz/Anula : 26/06/13	Modif. / Änderung : Mise à jour / Update / Aktualisierung / Actualización	Pièces de rechange Spare parts list Ersatzteilliste Piezas de repuesto
---	--	---

MOTEUR A AIR, modèle 340-2	AIR MOTOR, model 340-2	#
LUFTMOTOR, Modell 340-2	MOTOR DE AIRE, tipo 340-2	144.855.600

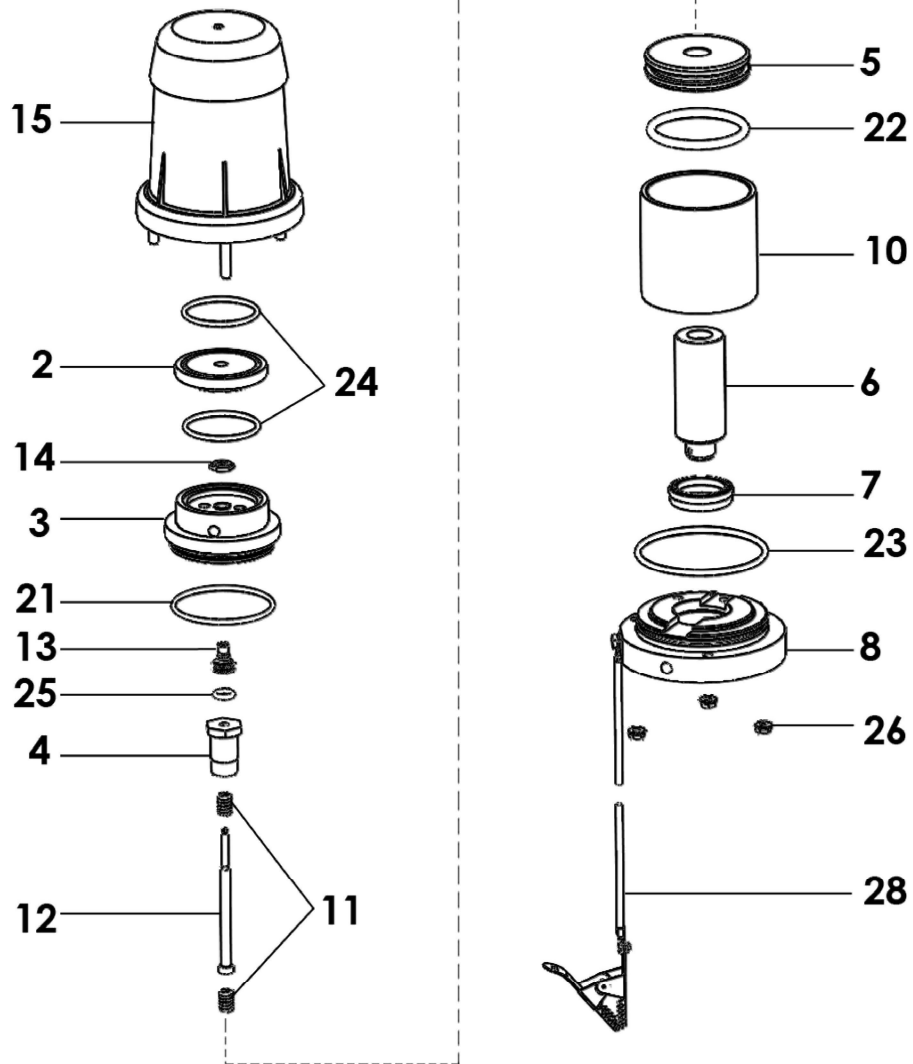
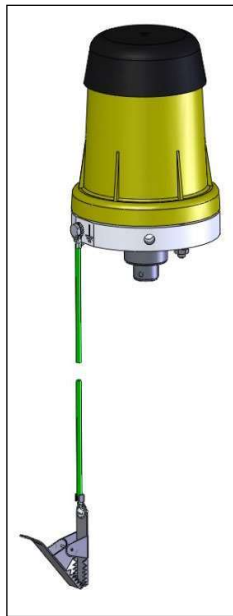



IMPORTANT : Respecter le **couple de serrage de 4mN maxi** sur les écrous (26).
 Comply with the **maximum screwing torque of 4 mN / 2.95 ft/lbs** on the nuts (26).
 Den Anziehmoment von 4 Nm maximal für die Muttern (26) entsprechen.
 Cumplir con el par de apriete de **4mN maxi** en las tuercas (26).

Ind	#	Désignation	Description	Bezeichnung	Denominación	Qté
2	044 850 108	Couvercle	Cover, reversing body	Deckel	Tapa	1
*3	044 850 107	Corps inverseur	Reversing body	Umschaltblock	Cuerpo inversor	1
4	044 550 006	Vis piston air	Screw, air piston	Kolbenschraube	Tornillo pistón de aire	1
5	044 850 105	Piston air supérieur	Upper air piston	Luftkolbenoberteil	Pistón aire superior	1
6	044 850 102	Piston air inférieur	Lower air piston	Luftkolbenunterteil	Pistón aire inferior	1
7	109 210 401	Joint U (par 10)	U seal (pack of 10)	U-Dichtring (10er Pack)	Junta U (x 10)	1
8	044 850 101	Corps fond de cylindre	Lower support	Flansch	Tapa base cilindro	1
10	044 850 106	Cylindre air	Air cylinder	Luftzylinder	Cilindro aire	1
*11	144 855 698	Ressort (par 2)	Spring (pack of 2)	Feder (2er Pack)	Muelle (x 2)	1
12	044 850 103	Tige de commande assemblée	Control rod assembly	Steuerstange	Eje de mando equipado	1
13	044 940 051	Porte-joint	Seal holder	O-Ring-Halter	Porta- junta	1
14	044 550 013	Clapet	Valve	Umsteuerventil	Válvula de aire	1
*15	144 855 605	Cloche	Cover	Glocke	Campana	1
21	909 420 259	Joint O Ring	O Ring	Dichtring	Junta O Ring	1
22	909 130 438	Bague R36	Ring, R36	O-Ring R36	Junta R36	1
23	909 420 108	Joint O Ring	O Ring	O-Ring	Junta O Ring	1
24	909 420 220	Joint O Ring	O Ring	O-Ring	Junta O Ring	2
25	109 130 311	Bague R 9 (par 10)	Ring, R 9 (pack of 10)	O-Ring, R 9 (10er Pack)	Junta R 9 (x 10)	1
26	906 011 501	Ecrou M6	Nut, M6	Mutter, M6	Tuerca, M6	3
28	901 180 024	Câble de mise à la terre (Lg. 5 m)	Cable, ground (Length : 5m / 16.4 ft)	Erdungskabel (Länge : 5m)	Cable de puesta a tierra (5m de largo)	1

Ind	#	Désignation	Description	Bezeichnung	Denominación	Qté
*	144 850 150	Pochette de maintenance (rep. 7, 11, 14, 21, 22, 23, 24, 25)	Servicing kit (ind. 7, 11, 14, 21, 22, 23, 24, 25)	Servicekit (beinhaltet Pos. 7, 11, 14, 21, 22, 23, 24, 25)	Bolsa de reparación (ind. 7, 11, 14, 21, 22, 23, 24, 25)	1
*	144 855 696	Kit vis piston air + tige de commande (rep. 4, 12)	Screw, air piston + control rod kit (ind. 4, 12)	Kolbenschraube + Steuerstangekit (beinhaltet Pos. 4, 12)	Kit tornillo pistón aire + eje de mando (ind. 4, 12)	1
*	144 855 697	Kit inverseur (rep. 13, 14, 25)	Reversing kit (ind. 13, 14, 25)	Umsteuerkit (beinhaltet Pos. 13, 14, 25)	Kit inversor (ind. 13, 14, 25)	1

* Pièces de maintenance préconisées.

* Preceding the index number denotes a suggested spare part.

* Bezeichnete Teile sind empfohlene Ersatzteile.

* Piezas de mantenimiento preventivas.

N C : Non commercialisé.

N S : Denotes parts are not serviceable.

N S : Bezeichnete Teile gibt es nicht einzeln, sondern nur komplett.

N S : no suministrado.

Doc. 573.420.050 Date/Datum/Fecha : 19/09/13 Annule/Cancela/ Ersetzt/Anula : 26/06/13	Modif. / Änderung : + Ind. / Pos. 23 + option / opción	Pièces de rechange Spare parts list Ersatzteilliste Piezas de repuesto
---	--	---

HYDRAULIQUE, modèle EOS C-18 (Entrée produit M 26x125)	FLUID SECTION, model EOS C-18 (Material inlet M 26x125)
HYDRAULIKTEIL, Modell EOS C-18 (Materialeingang M 26x1,25 AG)	HIDRÁULICA, tipo EOS C-18 (Entrada producto M 26x125)

HYDRAULIQUE, modèle EOS C-18 (Entrée produit F 1/2)	FLUID SECTION, model EOS C-18 (Material inlet F 1/2)
HYDRAULIKTEIL, Modell EOS C-18 (Materialeingang IG 1/2)	HIDRÁULICA, tipo EOS C-18 (Entrada producto H 1/2)

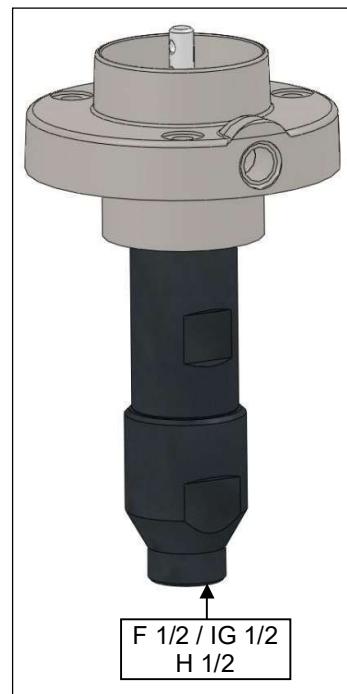
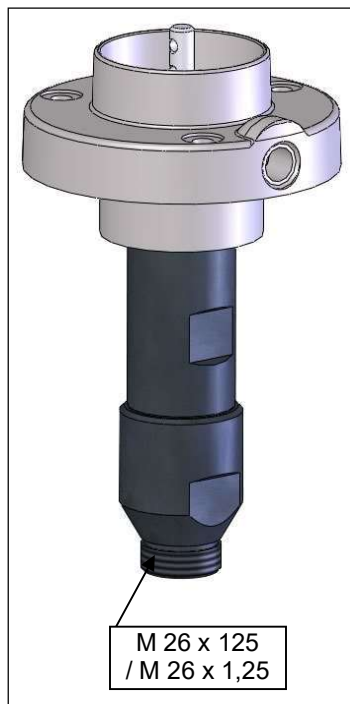

HYDRAULIQUE, modèle EOS C-18 (Entrée produit M 26x125)	FLUID SECTION, model EOS C-18 (Material inlet M 26x125)	#
HYDRAULIKTEIL, Modell EOS C-18 (Materialeingang M 26x1,25 AG)	HIDRÁULICA, tipo EOS C-18 (Entrada producto M 26x125)	144.855.700

HYDRAULIQUE, modèle EOS C-18 (Entrée produit F 1/2)	FLUID SECTION, model EOS C-18 (Material inlet F 1/2)	#
HYDRAULIKTEIL, Modell EOS C-18 (Materialeingang IG 1/2)	HIDRÁULICA, tipo EOS C-18 (Entrada producto H 1/2)	144.855.750

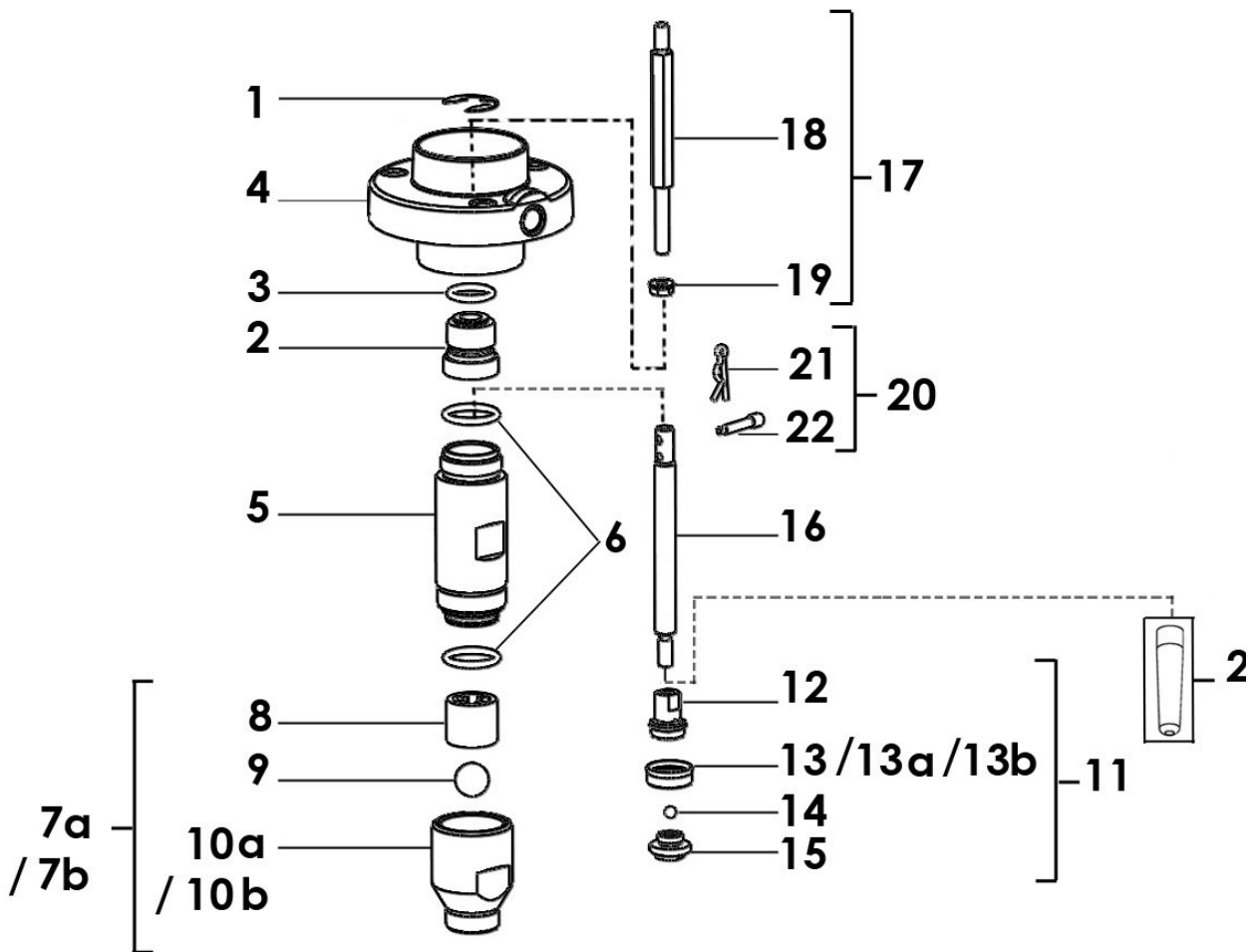

Pièces communes - Common parts - Gleiche Teile - Partes comunes

Ind	#	Désignation	Description	Bezeichnung	Denominación	Qté
*-	144 030 157	Cartouche GT équipée	Cartridge kit with GT seal, stainless	Packung Edelstahl mit GT-Dichtung	Cartucho GT equipado	1
1	902 201 116	▪ Anneau truarc	▪ Retaining ring	▪ Sicherungsring	▪ Anillo truarc	1
2	N C / N S	▪ Cartouche inox avec joint GT	▪ Cartridge with GT seal (stainless steel)	▪ Packung Edelstahl mit GT-Dichtung	▪ Cartucho inox con junta GT	1
3	144 589 500	▪ Joint de cartouche (x 10)	▪ Seal (pack of 10)	▪ Dichtring (10 St.)	▪ Junta (bolsa de 10)	1
23	144 855 798	▪ Flamme : outillage pour montage garniture supérieure	▪ Tool for upper packing assembly	▪ Werkzeug für die Montage der oberen Packung	▪ Herramienta para montar guarnición superior	1
4	044 855 701	Bride produit	Outlet flange	Flansch	Brida salida	1
*5	144 855 702	Cylindre inox + joint (ind. 6)	Cylinder (stainless) + seal (ind. 6)	Materialzylinder mit O-Ring (Pos. 6)	Cilindro inox + junta (ind. 6)	1
6	144 585 354	▪ Joint (x 10)	▪ Seal (x 10)	▪ O-Ring (Satz à 10 St.)	▪ Junta (bolsa de 10)	2
*11	144 850 151	Clapet de refoulement assemblé	Exhaust valve assembly	Druckventil komplett	Válvula expulsión completa	1
12	044 805 401	▪ Support de clapet	▪ Valve holder	▪ Druckventilgehäuse	▪ Soporte de válvula	1
13	044 765 503	▪ Joint de clapet en PFA	▪ Valve seal, PFA	▪ Kolbenmanschette, PFA	▪ Junta de válvula en PFA	1
14	907 414 108	▪ Bille Ø 5 inox	▪ Ball Ø 5 (stainless steel)	▪ Kugel (Edelstahl), Ø 5	▪ Bola Ø 5, inox	1
15	044 805 402	▪ Siège	▪ Seat	▪ Druckventilsitz	▪ Asiento	1
16	044 580 002	Tige de piston produit	Fluid piston rod	Kolbenstange	Eje de pistón producto	1
*	144 855 799	Pochette de maintenance (rep. 6, 9, 13, 14)	Servicing kit (ind. 6, 9, 13, 14)	Wartungssatz (Pos. 6, 9, 13, 14)	Bolsa de reparación (ind. 6, 9, 13, 14)	1

Pièces spécifiques - Specific parts - Spezifische Teile - Partes específicas

*7a	144 855 705	Clapet d'aspiration assemblé M 26x125	Suction valve assembly M 26x125	Ansaugventil komplett M 26 x 1,25 AG	Válvula aspiración completa M 26x125	1
8	044 931 003	▪ Cage de bille	▪ Ball cage	▪ Kugelkäfig	▪ Jaula de bola	1
9	907 414 242	▪ Bille Ø 16 inox	▪ Ball Ø 16 (stainless steel)	▪ Kugel, Edelstahl Ø 16	▪ Bola Ø16 inox	1
10a	NC / NS	▪ Pied de pompe M 26x125	▪ Pump foot M 26x125	▪ Ansaugventil M 26 x 1,25 IG	▪ Pie de bomba M 26x125	1

*7b	144 855 710	Clapet d'aspiration assemblé F 1/2	Suction valve assembly F 1/2	Ansaugventil komplett IG 1/2	Válvula aspiración completa H 1/2	1
8	044 931 003	▪ Cage de bille	▪ Ball cage	▪ Kugelkäfig	▪ Jaula de bola	1
9	907 414 242	▪ Bille Ø 16 inox	▪ Ball Ø 16 (stainless steel)	▪ Kugel, Edelstahl Ø 16	▪ Bola Ø16 inox	1
10b	NC / NS	▪ Pied de pompe F 1/2	▪ Pump foot F 1/2	▪ Ansaugventil IG 1/2	▪ Pie de bomba H 1/2	1

OPTION - OPTIONAL - OPTION - OPCIÓN

Ind	#	Désignation	Description	Bezeichnung	Denominación	Qté
13a	144 850 157	Joint de clapet en polyacétale	Valve seal, polyacetal	Kolbenmanschette in Polyacetal	Junta de válvula en poliacetato	1
13b	144 855 704	Joint de clapet PU rouge	Valve seal, PU (red)	Kolbenmanschette in PU (rot)	Junta de válvula en PU (rojo)	1
17	144 855 551	Kit tirants et écrous	Tie-rods and nuts kit	Stehbolzen und Mutter	Kit tirantes y tuercas	3
18	NC / NS	▪ Tirant	▪ Tie-rod, connecting	▪ Stehbolzen	▪ Tirantes	3
19	906 011 501	▪ Ecrou	▪ Nut	▪ Mutter	▪ Tuerca	3
20	144 855 501	Kit accouplement	Axis with pin	Achse mit Splint	Kit acoplamiento	1
21	NC / NS	▪ Goupille	▪ Pin	▪ Splint	▪ Pasador	1
22	NC / NS	▪ Axe	▪ Axis	▪ Achse	▪ Eje	1

ACCESSOIRES - ACCESSORIES - ZUBEHÖR - ACCESORIOS



Ind	#	Désignation	Description	Bezeichnung	Denominación	Qté
23	144 855 798	Flamme : outillage pour montage garniture supérieure	Tool for upper packing assembly	Werkzeug für die Montage der oberen Packung	Herramienta para montar guarnición superior	1

* Pièces de maintenance préconisées.

* Preceding the index number denotes a suggested spare part.

* Bezeichnete Teile sind empfohlene Ersatzteile.

* Piezas de mantenimiento preventivas.

N C : Non commercialisé.

N S : Denotes parts are not serviceable.

N S : Bezeichnete Teile gibt es nicht einzeln, sondern nur komplett .

N S : no suministrado.

<p>Doc. 573.418.050 Date/Datum/Fecha : 14/05/18 Annule/Cancel/ Ersetzt/Anula : 04/11/16</p>	<p>Modif. / Änderung : Mise à jour / Update / Aktualisierung / Actualización</p>	<p>Pièces de rechange Spare parts list Ersatzteilliste Piezas de repuesto</p>
---	---	--

EQUIPEMENT D'AIR	AIR SUPPLY	#
LUFTAUSRÜSTUNG	EQUIPO DE AIRE	151.665.655

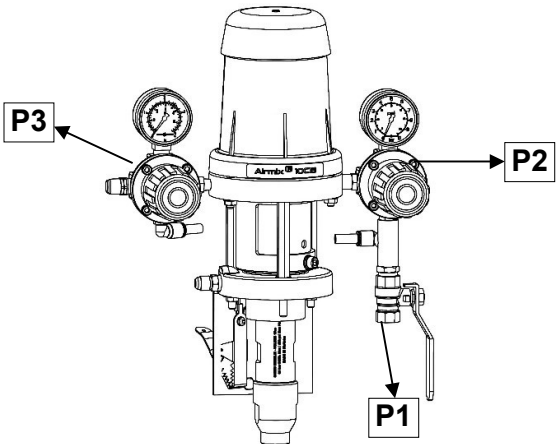

P1 = 6 bar max. / 87 psi
P2 = 0 → 5,5 bar / 0 → 80 psi
 (air de puissance / power air / Arbeitsluft / aire de potencia)
P3 = 0 → 3,5 bar / 0 → 50.7 psi
 (air de pulvérisation / spraying air / Zerstäuberluft / aire de pulverización)

Ind. 9

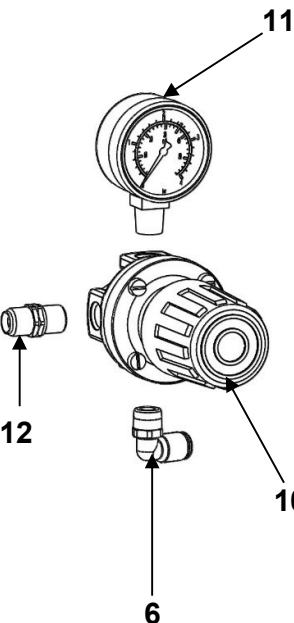
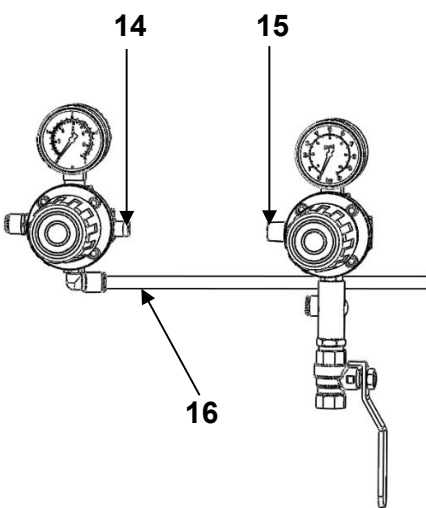
Ind. 1

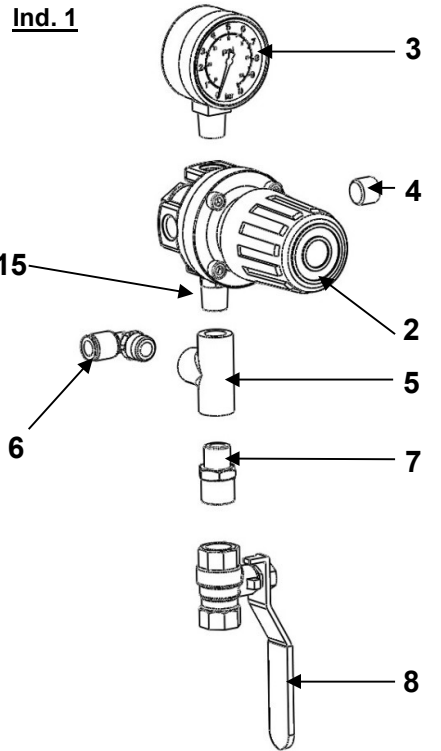

Ind	#	Désignation	Description	Bezeichnung	Denominación	Qté
1	151 665 658	Equipement d'air puissance	Power air supply	Luftausrüstung Arbeitsluft	Equipo de aire potencia	1
*2	016 370 500	▪ Détendeur d'air 1/4 - 5,5 bar - volant phosphore	▪ Air regulator, model 1/4 5.5 bar / 79.77 psi - knob (pantone 382 colour)	▪ Druckminderer, 1/4 - 5,5 bar (pantone 382 Stellglocke)	▪ Manorreductor de aire, tipo 1/4 - 5,5 bar - pomo de color pantone 382	1
*3	910 011 402	▪ Manomètre 0 - 10 bar	▪ Gauge, model 0 - 10 bar / 0 - 145 psi	▪ Manometer, 0-10 bar	▪ Manómetro, tipo 0-10 bar	1
4	906 333 102	▪ Bouchon 8 x 13	▪ Plug, model 8 x 13	▪ Blindstopfen, 8 x 13	▪ Tapón, tipo 8 x 13	1
5	904 303 002	▪ Tê F 1/4 BSP	▪ Tee, model F 1/4 BSP	▪ T-Stück, F 1/4 BSP	▪ Te, tipo H 1/4 BSP	1
6	905 120 912	▪ Coude 1/4" G T6x8	▪ Elbow, model 1/4" G T6x8	▪ Winkelnippel 1/4"G T6x8	▪ Codo, tipo 1/4" G T6x8	1
7	904 523 003	▪ Raccord M 1/4 BSP - M 3/8 BSP	▪ Fitting, double male, 1/4 BSP - 3/8 BSP	▪ Doppelnippel, 1/4 BSP - 3/8 BSP	▪ Racor, tipo MM 1/4 BSP - 3/8 BSP	1
8	903 090 206	▪ Robinet F 3/8	▪ Valve, model F 3/8	▪ Absperrhahn, F 3/8	▪ Grifo, tipo H 3/8	1
15	050 102 213	▪ Raccord MM 1/4 BSP	▪ Fitting, double male, 1/4 BSP	▪ Doppelnippel, M 1/4 BSP	▪ Racor, tipo MM 1/4 BSP	1
9	151 665 659	Equipement d'air pulvérisation	Spraying air supply	Luftausrüstung Zerstäuberluft	Equipo de aire pulverización	1
*10	016 380 500	▪ Détendeur d'air 1/4 - 5,5 bar - volant noir	▪ Air regulator, model 1/4 5.5 bar / 79.77 psi - black knob	▪ Druckminderer, 1/4 - 5,5 bar (Schwarze Stellglocke)	▪ Manorreductor de aire, tipo 1/4 - 5,5 bar - pomo negro	1
*11	910 011 404	▪ Manomètre 0 - 4 bar	▪ Gauge, model 0 - 4 bar / 0 - 58 psi	▪ Manometer, 0-4 bar	▪ Manómetro, tipo 0-4 bar	1
12	050 102 624	▪ Raccord M 1/4 BSP - M 1/4 NPS	▪ Fitting, double male, 1/4 BSP - 1/4 NPS	▪ Doppelnippel, AG 1/4 BSP - 1/4 NPS	▪ Racor, tipo MM 1/4 BSP - 1/4 NPS	1
6	905 120 912	▪ Coude 1/4" G T6x8	▪ Elbow, model 1/4" G T6x8	▪ Winkelnippel 1/4"G T6x8	▪ Codo, tipo 1/4" G T6x8	1
14	904 523 001	Raccord MM 1/4 - 1/8	Fitting, double male, 1/4 - 1/8	Doppelnippel, 1/4 - 1/8	Racor, tipo MM 1/4 - 1/8	1
15	050 102 213	▪ Raccord MM 1/4 BSP	▪ Fitting, double male, 1/4 BSP	▪ Doppelnippel, M 1/4 BSP	▪ Racor, tipo MM 1/4 BSP	1
16	050 380 265	Tuyau 5,5 x 8 PU noir (lg. 5 m)	Hose, model 5.5 x 8 PU black (length : 5 m / 16.40 ft)	PU Schlauch 5,5 x 8 Schwarz (Länge : 5 m)	Tubería, tipo 5,5 x 8 PU negro (5 m de largo)	1

* Pièces de maintenance préconisées.

* Preceding the index number denotes a suggested spare part.

* Bezeichnete Teile sind empfohlene Ersatzteile.

* Piezas de mantenimiento preventivas.



**AIRMIX® PUMP
& AIRSPRAY PUMP
WITH DIFFERENTIAL AIR MOTOR
PREVENTIVE MAINTENANCE**

TRANSLATION FROM THE ORIGINAL MANUAL

IMPORTANT : Before assembly and start-up, please read and clearly understand all the documents relating to this equipment (professional use only).

THE PICTURES AND DRAWINGS ARE NON CONTRACTUAL. WE RESERVE THE RIGHT TO MAKE CHANGES WITHOUT PRIOR NOTICE.

SAMES KREMLIN SAS
13, chemin de Malacher
38 240 - MEYLAN - France
☎ : 33 (0)4 76 41 60 60

www.sames-kremlin.com

Before cleaning or removing components of the equipment, it is compulsory :

- 1 - to shut off the air supply,
- 2 - to open the fluid networks to depressurize the system,
- 3 - to shut off the machine electrical supply.

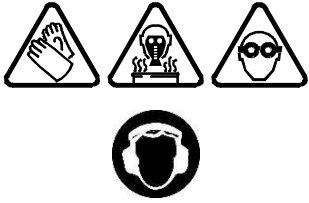

Protective clothing (gloves, protective masks, glasses, hearing protective earplug, protective clothing) should be worn to comply with the recommendations.

The working area must be correctly ventilated.

■ PUMP

Make sure that the pump is clean and in good condition to increase equipment working life.

If the pump is a standard one :

- Make sure the pump fluid outlet flange is always filled up with T lubricant (this T lubricant will normally be coloured by the paint). For that use the hole located on the transparent part of the protection housing.
- Regularly clean the wetting-cup with solvent after having drained the lubricant (Unscrew the plug placed at the upper flange).

**Guards (air motor cover, coupling shields, housings ...) have been designed for safe use of the equipment.
The manufacturer will not be held responsible for bodily injury or failure and / or damage to property due to removal or partial removal of the guards.**

Make sure that the suction strainer is clean and in good condition. Clean it regularly and replace it if it is necessary.

Flush the pump as often as necessary, specially when spraying pigment filled-material.

**Whatever the case, when stopping the pump, always leave it filled with material :
For a short duration shutdown, if the flushing has not been carried out, leave the pump filled with material.
For a long duration shutdown, after flushing, leave it filled with solvent.**

■ SPRAY GUN

Comply with the usual instructions of spray gun servicing (refer to spray gun manual).

■ FILTER

If the pump is equipped with a filter at the fluid outlet, comply with the usual instructions of filter servicing (refer to filter manual).



AIRMIX® PUMP & AIRSPRAY PUMP WITH DIFFERENTIAL AIR MOTOR TROUBLESHOOTING GUIDE

TRANSLATION FROM THE ORIGINAL MANUAL

IMPORTANT : Before assembly and start-up, please read and clearly understand all the documents relating to this equipment (professional use only).

THE PICTURES AND DRAWINGS ARE NON CONTRACTUAL. WE RESERVE THE RIGHT TO MAKE CHANGES WITHOUT PRIOR NOTICE.

SAMES KREMLIN SAS
13, chemin de Malacher
38 240 - MEYLAN - France
☎ : 33 (0)4 76 41 60 60

www.sames-kremlin.com

Guards (air motor cover, coupling shields, housings ...) have been designed for safe use of the equipment.

The manufacturer will not be held responsible for bodily injury or failure and / or damage to property due to removal or partial removal of the guards



CAUTION :

Before any intervention on the equipment, shut off the air supply and follow the general safety instructions. Open the drain or the gun to depressurize the gun. The ram must be in the low position.

CAUSE	SOLUTION
The pump does not start	Check the pump air supply.
Priming trouble : → Air is always coming out from the spray gun → When priming, air (or material) does not come out from the spray gun	Be sure that the spray gun is fully opened and air evacuated through this one. Air intake at the fitting or at the suction rod. Check the pump valves. If a valve is stucked by dry paint, it can be unsticked without disassembling it. Blow air pressure directly by suction fitting.
The pump does not stop at once when shutting off the spray gun : → The pump stops only on down stroke → The pump stops only on up stroke	Check exhaust valve or valve seal. Check suction valve or upper cartridge.
The pump locks with an air leakage to the motor	Check the motor valve under the cover.
On Intensive™ pump, the lubricant into the cup is fastly coloured and its level increases	Check the upper packing (tighten the cup or change seals if it is necessary).
Spraying trouble	Refer to spray gun manual.



**AIRMIX® PUMP
& AIRSPRAY PUMP
WITH DIFFERENTIAL AIR MOTOR
OPERATING PRINCIPLE AND START-UP**

TRANSLATION FROM THE ORIGINAL MANUAL

IMPORTANT : Before assembly and start-up, please read and clearly understand all the documents relating to this equipment (professional use only).

THE PICTURES AND DRAWINGS ARE NON CONTRACTUAL. WE RESERVE THE RIGHT TO MAKE CHANGES WITHOUT PRIOR NOTICE.

SAMES KREMLIN SAS
13, chemin de Malacher
38 240 - MEYLAN - France
 : 33 (0)4 76 41 60 60
www.sames-kremlin.com

1. OPERATING PRINCIPLE

The pump (A) consists of :

- an alternating air motor (B),
- an hydraulic section (C) mechanically coupled to the air motor (B).

The air motor is supplied with compressed air by means of the regulator (D) (pantone 382 colour knob). The pressure is read on the gauge (E).

During its alternating movement, the air motor drives the piston of the hydraulic section (C). The fluid is drawn in (L) and forced under pressure in (N). Due to its design, this pressure is always the one read on the gauge (E) x pump ratio.

The spray air pressure of the gun is adjusted by means of the regulator (black knob) (F) and the pressure can be read on the gauge (G).

- To adjust the fluid flow rate, turn the pantone 382 colour knob (D) - (Gauge E).
- To adjust the spray air, turn the black knob (F) - (Gauge G).

2. START-UP

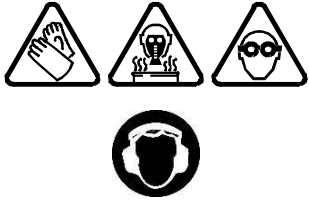

Protective clothing (gloves, protective masks, glasses, hearing protective earplug, protective clothing) should be worn to comply with the recommendations.

The working area must be correctly ventilated.

2-1 FILLING

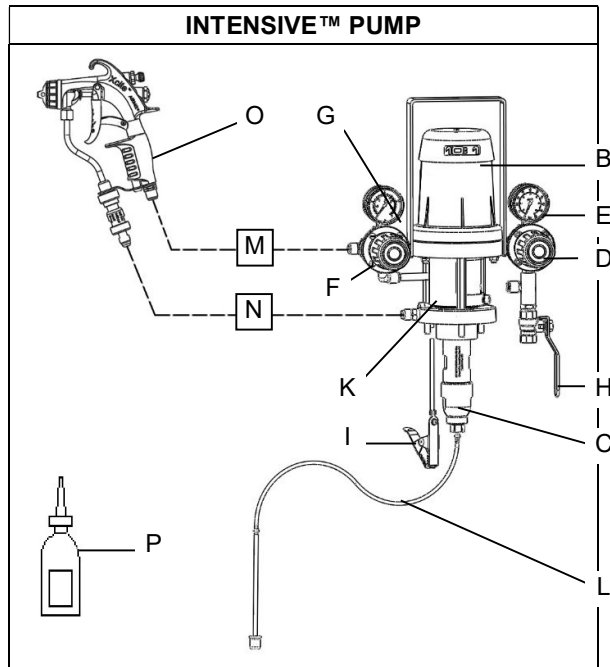

Captions :

A	Intensive™ pump (B + C)	K	Spring or protection carter
B	Motor	L	Suction rod
C	Fluid section	M	Air static (static conductor)
D	'MOTOR AIR' regulator	N	HP fluid section
E	Gauge	O	AIRMIX® gun or airspray gun
F	'GUN AIR' regulator	P	T lubricant (125 ml / 4.4 oz)
G	Gauge		
H	Air inlet valve		
I	Ground		

(For specific installation, please contact your SAMES KREMLIN representative).

Guards (air motor cover, coupling shields, housings ...) have been designed for safe use of the equipment.
The manufacturer will not be held responsible for bodily injury or failure and / or damage to property due to removal or partial removal of the guards

Start up procedure :

- 1 - Ground the pump.
- 2 - **If the pump is an Intensive™ one, fill the wetting cup (S) with T lubricant (P) or with an appropriate cleaning solvent.**
- 3 - Unscrew the air regulators (D and F).
- 4 - Interconnect the equipment with the air pressure network (clean and dry air - P < 6 bar / 87 psi). Install a water drop, model 3/8 if it is necessary.
- 5 - Connect all the hoses (air hose and fluid hose) as well as the gun (O).
- 6 - Remove the gun air cap by unscrewing the cap ring and nozzle (only in case of an Airmix® gun).

▪ **FLUSHING WITH SOLVENT**

- 7 - Immerse suction rod (L) into material container.
- 8 - Open pump air pressure valve (H).
- 9 - Point the spray gun, not supplied with air, towards the material container and press the trigger.
- 10 - Increase **gradually** the air regulator (D) so that the pump runs slowly (Pressure between 0.5 and 1 bar / 7.25 to 14.5 psi). When material flows out regularly, release the trigger.

▪ **PRIMING WITH MATERIAL**

- 11 - Remove suction rod (L) from material container and immerse it in a solvent-filled container (take all appropriate precautions in the presence of flammable solvents).
- 12 - Point the spray gun, not supplied with air, towards the material container and trigger the gun until the material flows out regularly.

▪ **WORK**

- 13 - Reinstall the ring, the aircap and the nozzle (only in case of an Airmix® gun) on gun.
- 14 - Adjust air regulator (D) to get the appropriate material pressure and flow rate.
- 15 - **Gradually** open air regulator (F) to adjust spraying air to obtain the required spray pattern.

2-2 PUMP SUPPLIED IN GRAVITY

➡ **CAUTION: The pumps can be supplied in gravity but not in filling.**

Interconnect the pump fluid inlet with the gravity cup supply hose and start up the pump as previously indicated.

3. SHUTDOWN AT THE END OF THE WORK

▪ SHORT DURATION SHUTDOWN

- 1 - Decrease the material pressure of air regulator (D) until reading **0 bar / 0 psi** on gauge (E).
- 2 - Trigger the gun to depressurize the system.
- 3 - Unscrew the gun air regulator (F) or disconnect the gun air inlet.
- 4 - Remove the gun air cap and the nozzle (only in case of an Airmix® gun) of the spray gun and soak it into solvent.

▪ LONG DURATION SHUTDOWN

- 1 - Decrease the material pressure of air regulator (D) until reading **1 bar / 14.503 psi** on gauge (E).
- 2 - Unscrew the gun air regulator (F) or disconnect the gun air inlet.
- 3 - Remove the gun air cap and the nozzle (only in case of an Airmix® gun) from the spray gun and soak it into solvent.
- 4 - Remove the suction rod from the material container and immerse it in a solvent-filled container. Take all the appropriate precautions in the presence of flammable solvents.
- 5 - Point the gun towards the container and trigger the gun. When the solvent flows out, point the gun towards the recovery container.
- 6 - When the solvent flows out clean, release the gun trigger.
Nota : If the pump is an Intensive™ one, release the spray gun trigger when the pump piston is in a low position. To prevent from damaging the seals when starting once again the pump, the piston must be immersed into solvent.
- 7 - Fully unscrew the air regulator (D) and shut off the compressed air valve (valve H).
- 8 - Trigger the spray gun to decompress the hoses. Therefore, the pump and the hose remain filled with solvent at the atmospheric pressure.

4. SAFETY DEVICE

**Guards (air motor cover, coupling shields, housings ...) have been designed for safe use of the equipment.
The manufacturer will not be held responsible for bodily injury or failure and / or damage to property due to removal or partial removal of the guards**

AIRMIX® pump : A relief-valve (setting : 6.5 bar / 94 psi) is fitted on the pump air motor - thus protecting this one from an overpressure which could damage it.

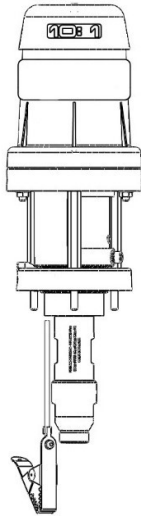

AIRMIX® PUMP

10-C18

TECHNICAL FEATURES

TRANSLATION FROM THE ORIGINAL MANUAL

IMPORTANT : Before assembly and start-up, please read and clearly understand all the documents relating to this equipment (professional use only).

THE PICTURES AND DRAWINGS ARE NON CONTRACTUAL. WE RESERVE THE RIGHT TO MAKE CHANGES WITHOUT PRIOR NOTICE.

SAMES KREMLIN SAS

13, chemin de Malacher
38 240 - MEYLAN - France
☎ : 33 (0)4 76 41 60 60

www.sames-kremlin.com

1. DESCRIPTION

- Compact pneumatic pump.

- Ease of use and maintenance.

Recommended for :

- Supplying an AIRMIX® spray gun,
- Solvanted paints, water-based paints (Nitro, Polyurethan, Polyester), shades (material viscosity : from 80 to 530 mPa.s).

2. TECHNICAL FEATURES

Motor type340-2	Air motor stroke	45 mm	1" - 25/32
Pump body typeC-18	Air motor section	35 cm ²	5.5 sq.in
Theoretical pressure ratio10/1	Fluid section	3,9 cm ²	0.6 sq.in
Real pressure ratio10/1	Delivery per cycle	18 cm ³	0.6 oz
Weight (wall mounted pump without suction rod)5.3 kg / 12 Lbs	Number of cycle	55 per liter	210 per gallon
	Fluid delivery (30 cycles)	0,55 l	0.14 US gal
	Maximum air inlet pressure	6 bar	87 psi
	Maximum fluid discharge pressure	60 bar	870 psi
	Weighted sound pressure (LAeq)	79,4 dBa	79.4 dBa
	Maximum fluid temperature	60°C	140°F
	Maximum ambient temperature	40°C	104°F

Wetted parts :

Hard chrome stainless steel,
Treated stainless steel,
Stainless steel

Test conditions :

- Test duration : 30 s,
- Nb of cycles/min : 20,
- Motor air pressure : 6 bar / 87 psi,
- Material used : water,
- Gun : Xcite™.

Tightness packings	Upper, fixed	Lower, mobile
standard	Stainless steel cartridge with GT seal	PFA seal
optional	Stainless steel cartridge with seal, charged PTFE (recommended for : - fluid with a viscosity lower than 30 Cps - or solvents with a motor air pressure lower than 2,5 bar / 36.26 psi - or fluids very hard to flush, like PU)	Polyacetale seal

▪ **FITTINGS FLUID SECTION C18 M 26 X 125**

		Bare pump	Pump assembly
Air	Inlet	F 1/4" BSP	F 3/8" BSP (valve)
	Outlet	-	M 1/4" NPS (spraying air)
Fluid	Inlet	M 26 x 125	Suction rod
	Outlet	F 1/4" NPS	M 1/2" JIC

▪ **FITTINGS FLUID SECTION C18 F 1/2**

		Bare pump	Pump assembly
Air	Inlet	F 1/4" BSP	F 3/8" BSP (valve)
	Outlet	-	M 1/4" NPS (spraying air)
Fluid	Inlet	F 1/2" G	Suction rod
	Outlet	F 1/4" NPS	M 1/2" JIC

▪ **HOSES WITH FITTINGS**

Pump air supply hose (minimum \varnothing for a 5m / 16 ft length) :	\varnothing 7 mm
Air hose (between "AIR GUN" air regulator and spray gun) : int.	\varnothing 7 mm
AIRMIX® fluid hose (between fluid outlet of the pump and spray gun) : int.	\varnothing 4,8 mm

▪ **DIMENSIONS**

Ind.	mm	Inch.	Ind.	mm	Inch.	Ind.	mm	Inch.	Ind.	mm	Inch.
A	278.5	11	B	\varnothing 120	\varnothing 4.7	C	392.5	15.45	D	198	7.8
F	60	2.36	G	100	3.9	H	65	2.56	I	10	0.4
J	43	1.7	K	\varnothing 7X15	0.27x0.6	L	\varnothing 7	\varnothing 0.27	M	48	1.9
N	45	1.8	O	9	0.35	P	72	2.83	Q	90	3.6

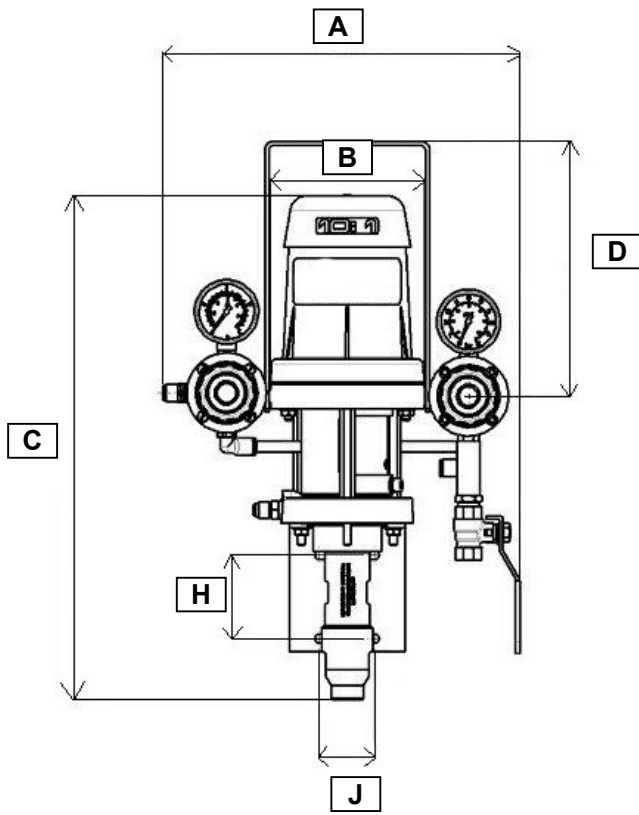

Wall mounted bracket

ABOVE VIEW

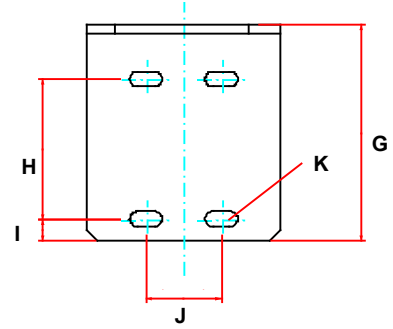

FRONT VIEW

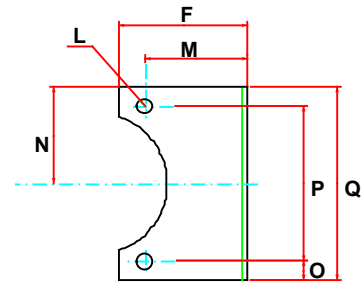



3. INSTALLATION

The pumps are designed to be installed in a spray booth.

■ DESCRIPTION OF THE LABEL MARKING

Marking in accordance with the ATEX regulation



Sigle SAMES KREMLIN	Manufacturer brand
Made in France	Country of manufacture
CE 	CE : European conformity  : For use in explosive area II : group II 2 : class 2 G : gas Surface equipment meant to an area where explosive atmospheres due to gas, vapours, mists are liable to appear from time to time in usual operating.
Ex h IIA TX	Ex : Marking of conformity with European standards h : Mode of protection for non electrical device IIA : Gas group TX : Temperature class - Maximum surface temperature : See table below*
Gb	Gb : Equipment protection level (Gas zone1)
Type de pompe / Pump type	Pump version
Rapport de pression / Pressure ratio	Pump pressure ratio
Débit par cycle / Fluid flow per cycle	Fluid section capacity
Pression air max. / Max. air pressure	Maximum pump motor air supply maximum
Pression prod max. / Max. fluid pressure	Maximum fluid pressure at the outlet of the pump
Numéro de série / Serial number	Number given by SAMES KREMLIN. The four first numbers indicate the manufacturing year.

■ TEMPERATURE CLASS

Temperature class	Maximum surface temperature
T4	127.7° C / 261.8° F

■ INSTALLATION DIAGRAM

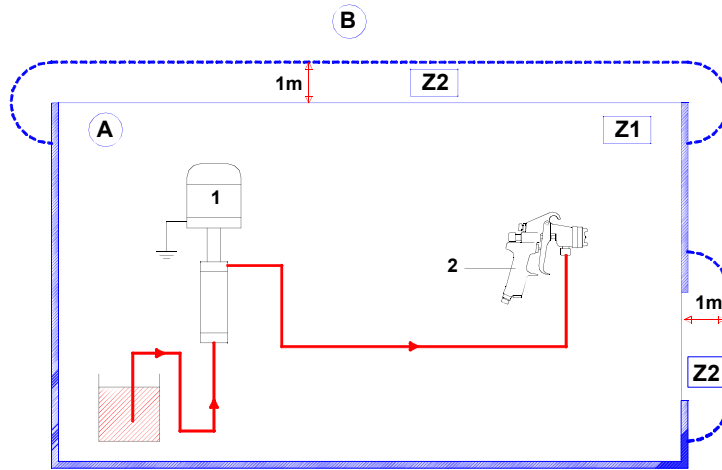

Ind.	Description
A	Explosive area Area 1 (Z1) or Area 2 (Z2) : spray booth
B	Non explosive area

Ind.	Description
1	Pump
2	Gun



The 1 m / 39.37" distance indicated in the diagram is given for information purposes only and hold harmless to SAMES KREMLIN. The user is responsible for the extraction and conditioning of the painting area where the equipment is used, for working conditions conditions (refer to EN 60079-10 standard). The 1 m / 39.37" distance may be modified if trials carried out by the user deem this necessary.



Please use a conductive air hose (minimum internal diameter : 7mm), for connecting the gun to the air regulator (capable of supplying at least 3 bar / 44 psi).

Please ensure when fitting the **high pressure** paint hose, between the gun and the pump. That the fittings are firmly tightened.



NB : In some particular cases, if the air hose (4) is a non-conductive hose, the fluid hose (3) must be conductive.

At least one of the 2 hoses (air or fluid) for the gun must be conductive.